

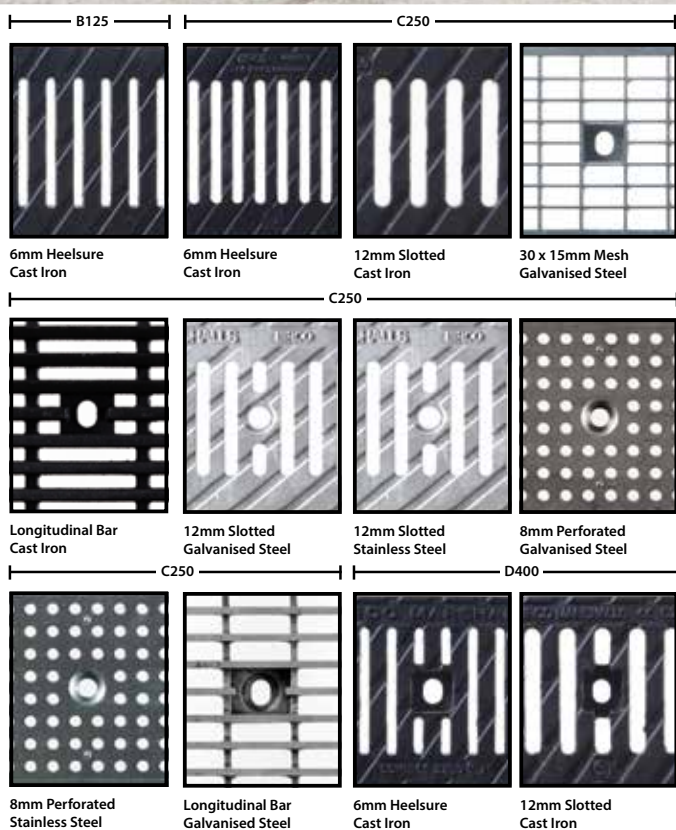

Drexus 100



Drexus 100 Grate Drainage System



Marshalls Drexus 100 is a cost effective lighter weight linear drainage system providing loading of up to D400 when used with the range of Drexus 100 cast Iron grates. With wall thicknesses of just 30mm, and its scalloped side walls this unit is the lightest within the Marshalls channel range.

Available for both pedestrian and standard trafficking applications, making it suitable for a variety of projects including civic, commercial and rail applications.

nssPlus
Q10 180

Drexus 100

Grate Drainage System

- Drexus 100 is a robust general purpose linear drainage system for applications up to and including Load classification D400 when used with the Drexus 100 grating.
- Available for both pedestrian and standard trafficking applications, making it suitable for a variety of projects including civic, commercial and rail applications.
- The system comprises a range of channels, gratings and in-line outfalls with a common junction outfalls.
- Drexus 100 benefits a wall thickness of 30mm, resulting in this unit being the lightest Marshalls channel within the range.
- Gratings are securely fixed to the channel units by bolting through the grating to locking bars fitted into preformed recesses under the galvanised angles.
- Drexus 100 uses high quality 4 mm solid steel angles with a 70µm zinc coating for corrosion resistance.
- Anchors stably connect the solid steel angles with the concrete channels making it possible to conduct sealing of the base courses directly at the channel/solid steel edge when laying the channels.
- The anchoring system of Drexus 100 channels firmly bond the drainage channel to the adjoining base structure. When professionally laid, this virtually excludes the possibility of the sway or disengagement of the channels from the base structure.
- In order to ensure a permanently stable connection between the individual channel units, all Drexus concrete channels are fitted with a DIN EN 1433-compliant safety sealing joint. Each safety sealing joint is visible from above, making inspection fast and easy
- 2 locking bars are provided per 1000mm length of channel.
- Drexus 100 channels are produced in 4 constant invert depths of 120, 145, 170, 195, 220mm – in 1000mm and 500mm channel lengths
- Channels with transition falls are available – 4 transition fall channels with a gradient to 2.5%. transition fall channels are 1000mm long

Robust concrete Drexus 100 channels are highly resistant to impact damage on site during the construction phase

Range of base depths and transition falls to provide efficient drainage for all project types.

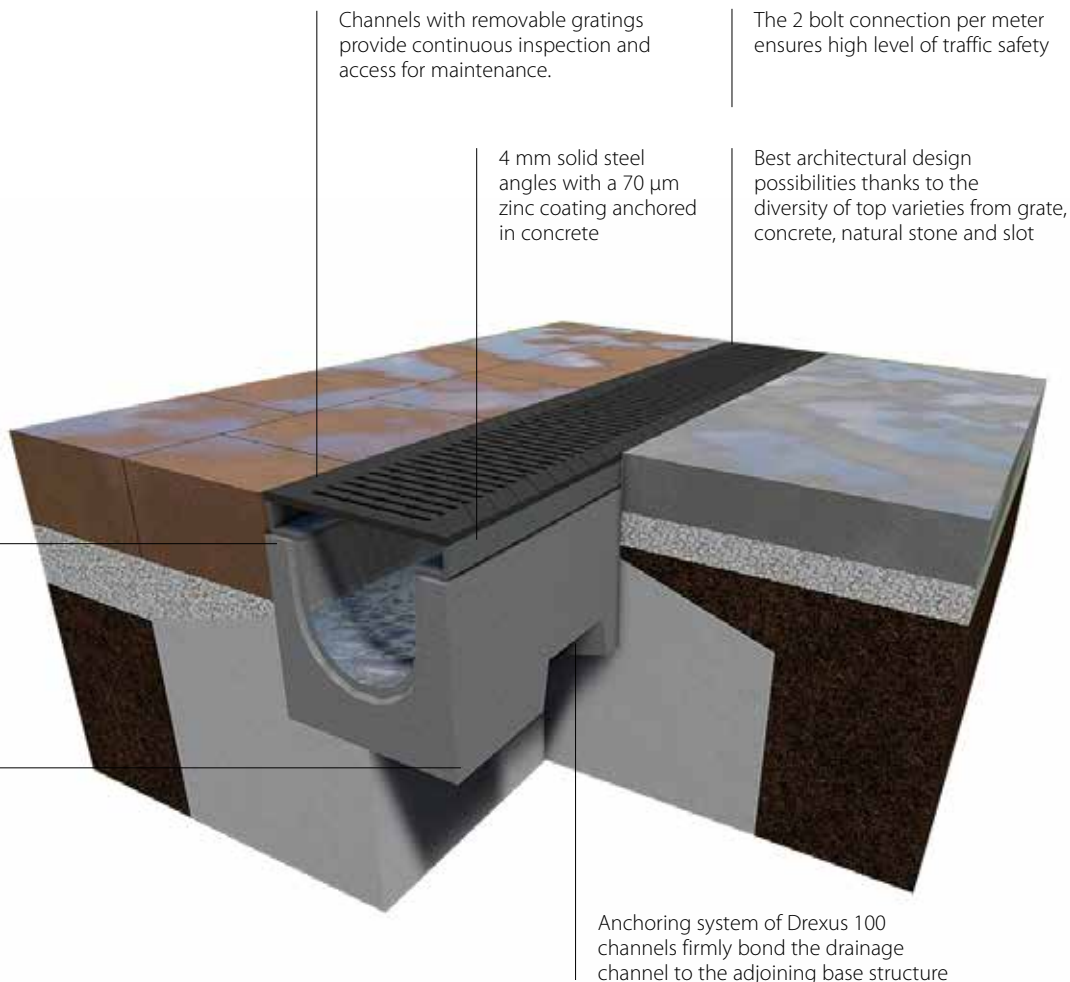

Drexus 100 Components

TOP COMPONENTS



Drexus 100 Gratings

BASE COMPONENTS

Base channels are available in 1000mm or 500mm lengths

BASE CHANNELS

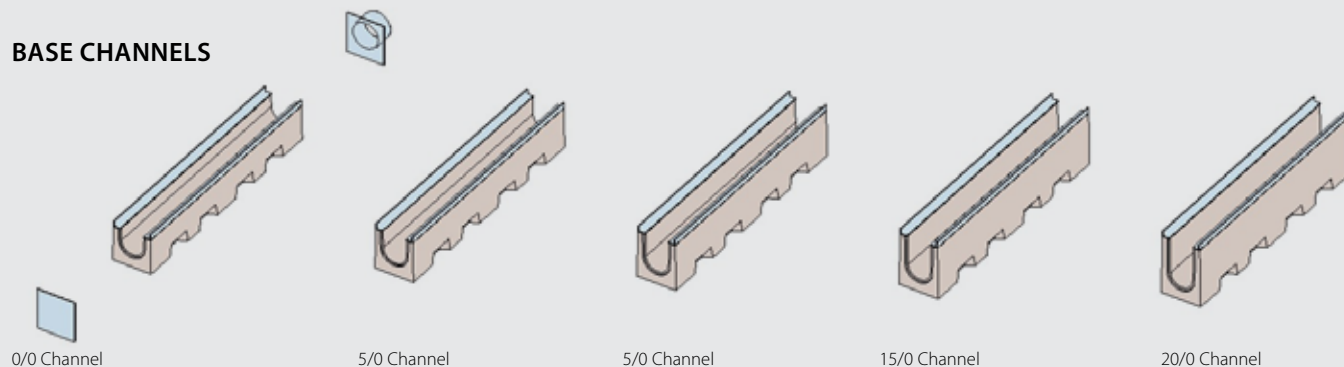

0/0 Channel

5/0 Channel

5/0 Channel

15/0 Channel

20/0 Channel

OUTFALLS

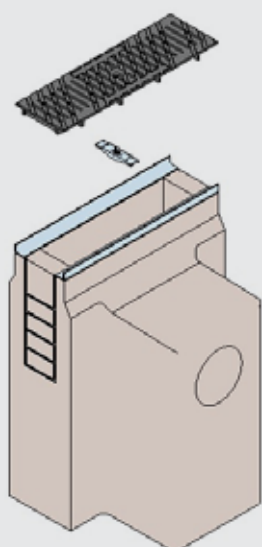

Inline Side Outlet Outfall

- A 2 section concrete trapped outfall, with an inlaid access cover and frame.
- Side outlet for 150mm diameter pipework with universal seal.
- Cut-out panels in the silt box allows Drexus 100 runs from both sides

Note: Drexus 100 grate available separately.

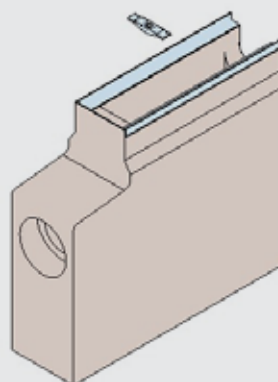

Inline End Outlet Outfall

- A 2 section concrete trapped outfall, with an inlaid access cover and frame.
- End outlet for 100mm diameter pipework with universal seal.
- Cut-out panels in the silt box allows Drexus 100 runs from both side.

Note: Drexus 100 grate available separately.

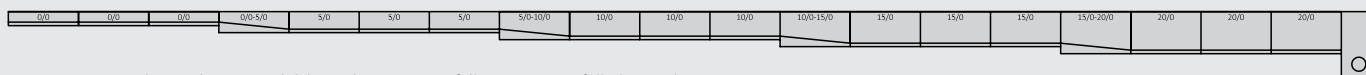

Drexus 100 channels are available with transition falls. Transition fall channels increase drainage discharge capacity by improving flow rates and thereby increasing the overall discharge capacity of the system. Transition falls are 1000mm long

Fig.11 Stepped constant depth channels laid on sloping ground

Hydraulic Data

FLOW CAPACITY

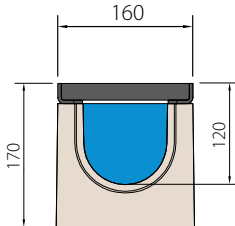
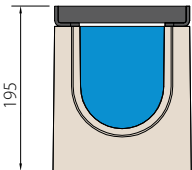
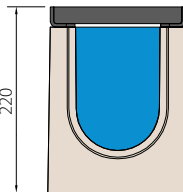
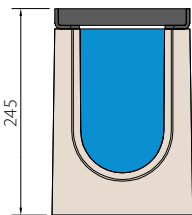
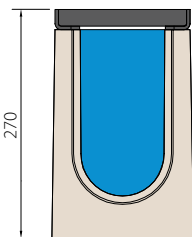
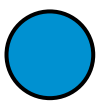
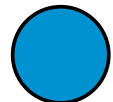
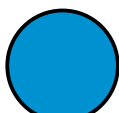
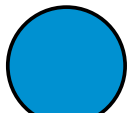
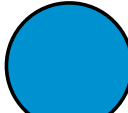
Drexus 100 0/0 Channel Unit	Drexus 100 5/0 Channel Unit	Drexus 100 10/0 Channel Unit	Drexus 100 15/0 Channel Unit	Drexus 100 20/0 Channel Unit
				
				
Equivalent Pipe Diameter (mm) 105	Equivalent Pipe Diameter (mm) 115	Equivalent Pipe Diameter (mm) 130	Equivalent Pipe Diameter (mm) 140	Equivalent Pipe Diameter (mm) 150

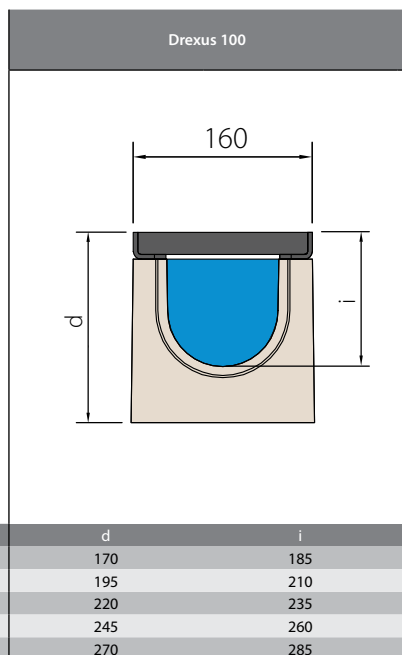

Hydraulic Data

Drexus 100										
Channel Type	0/0		5/0		10/0		15/0		20/0	
	l/s	m/s	l/s	m/s	l/s	m/s	l/s	m/s	l/s	m/s
10	27	3.02	35	3.15	44	3.25	53	3.31	62	3.36
20	19	2.13	25	2.23	31	2.29	37	2.33	43	2.37
30	15	1.74	20	1.81	25	1.87	30	1.9	35	1.93
40	13	1.5	18	1.57	22	1.62	26	1.65	31	1.67
50	12	1.34	16	1.4	20	1.44	24	1.47	27	1.5
75	10	1.09	13	1.14	16	1.18	19	1.2	22	1.22
100	8	0.94	11	0.99	14	1.02	17	1.04	19	1.05
150	7	0.77	9	0.8	11	0.83	13	0.84	16	0.86
200	6	0.66	8	0.69	10	0.72	12	0.73	14	0.74
300	5	0.54	6	0.56	8	0.58	9	0.59	11	0.6
400	4	0.47	5	0.49	7	0.5	8	0.51	10	0.52
500	4	0.42	5	0.43	6	0.45	7	0.46	8	0.46
750	3	0.34	4	0.35	5	0.36	6	0.37	7	0.38
1000	3	0.29	3	0.3	4	0.31	5	0.32	6	0.32
1500	2	0.23	3	0.25	3	0.25	4	0.26	5	0.26
2000	2	0.2	2	0.21	3	0.22	4	0.22	4	0.23
Equivalent pipe diameter	105mm		115mm		130mm		140mm		150mm	

Theoretical Outfall Capacities			
Outfall Type	Outlet Pipe Diameter	m/s	l/s
Drexus 100 Inline End Outlet Outfall	100mm	2.23	11
Drexus 100 Inline Side Outlet Outfall	150mm	2.39	26

Drexus 100 Component Codes

A Gratings

Gratings	Loading	Length (mm)	Width (mm)	Unit Weight (kg)	Item Code
6mm Heelsure Cast Iron	B125	500	153	3.8	DR544010
6mm Heelsure Cast Iron	C250	500	153	3.8	DR544020
12mm Slotted Cast Iron	C250	500	153	3.9	DR544030
30 x 15mm Mesh Galvanised Steel	C250	500	153	4.2	DR544170
30 x 15mm Mesh Galvanised Steel	C250	1000	153	8.4	DR544165
Longitudinal Bar Galvanised Steel	C250	500	153	2.8	DR544060
Longitudinal Bar Galvanised Steel	C250	1000	153	5.8	DR544070
Longitudinal Bar Cast Iron	C250	500	153	4.6	DR544080
8mm Perforated Galvanised Steel	C250	500	153	2.6	DR544090
8mm Perforated Galvanised Steel	C250	1000	153	5.3	DR544100
8mm Perforated Stainless Steel	C250	500	153	2.7	DR544110
8mm Perforated Stainless Steel	C250	1000	153	5.4	DR544130
12mm Slotted Galvanised Steel	C250	500	153	2.6	DR544140
12mm Slotted Galvanised Steel	C250	1000	153	5.4	DR544150
12mm Slotted Stainless Steel	C250	500	153	2.7	DR544160
12mm Slotted Stainless Steel	C250	1000	153	5.6	DR544180
6mm Heelsure Cast Iron	D400	500	153	4.5	DR544040
12mm Slotted Cast Iron	D400	500	153	4.95	DR544050

B Constant Depth Channels

Constant Depth Channels	Length (mm)	Width (mm)	Invert Width (mm)	Depth (mm)	Invert Depth (mm)	Unit Weight (kg)	Item Code
Channel 0/0	1000	160	100	170	120	38	DR540015
Channel 5/0	1000	160	100	195	145	46	DR540025
Channel 10/0	1000	160	100	220	170	54	DR540035
Channel 15/0	1000	160	100	245	195	62	DR540045
Channel 20/0	1000	160	100	270	220	70	DR540055
Channel 0/0	500	160	100	170	120	19	DR540515
Channel 5/0	500	160	100	195	145	23	DR540525
Channel 10/0	500	160	100	220	170	27	DR540535
Channel 15/0	500	160	100	245	195	31	DR540545
Channel 20/0	500	160	100	270	220	35	DR540555

C T Junction Channels

T Junction Channels	Unit Weight (kg)	Item Code
T-Channel 0/0	19	DR543700
T-Channel 10/0	27	DR543710
T-Channel 20/0	35	DR543720





D Channel Transitions

Channel Transitions	Length (mm)	Width (mm)	Invert Width (mm)	Depth (mm)	Invert Depth (mm)	Unit Weight (kg)	Item Code
0/0 - 5/0	1000	160	100	170/195	120/145	41	DR542010
5/0 - 10/0	1000	160	100	195/220	145/170	45	DR542020
10/0 - 15/0	1000	160	100	220/245	170/195	48	DR542030
15/0 - 20/0	1000	160	100	245/270	195/220	52	DR542040

Drexus 100 Channels are available with transitions. Transition Channels increase drainage discharge capacity by improving flow rates and thereby increasing the overall discharge capacity of the system. Transition channels are 1000mm long.

E End Cap/Cap Outlets

End Cap/Cap Outlets	Unit Weight (kg)	Item Code
End Cap 0/0	1	DR537910
End Cap 5/0	1.2	DR537920
End Cap 10/0	1.4	DR537930
End Cap 15/0	1.6	DR537940
End Cap 20/0	1.8	DR537950
Cap Outlet 0/0	1	DR538410
Cap Outlet 5/0	1.2	DR538420
Cap Outlet 10/0	1.4	DR538430
Cap Outlet 15/0	1.6	DR538440
Cap Outlet 20/0	1.8	DR538450

F Outfalls

Outfalls	Unit Weight (kg)	Item Code
Side Outfall	137	DR538510
End Outfall	101	DR538520

Drexus 100 with reference numbers indicated in **bold** black are available ex-stock. Drexus 100 with reference numbers indicated in light are manufactured to order. Contact our sales office to discuss your requirements.

Standard Details

Drawing 1 of 3

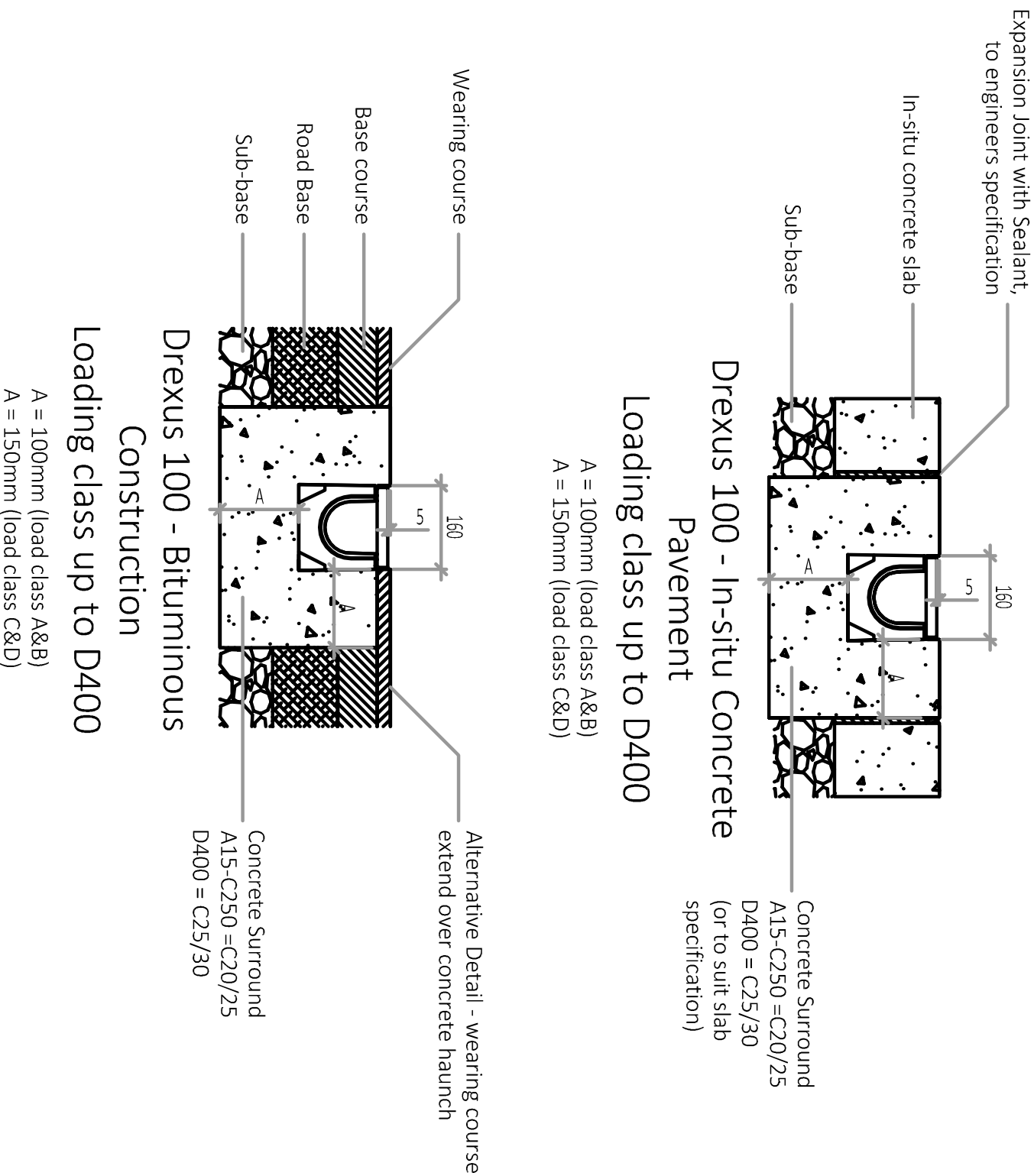

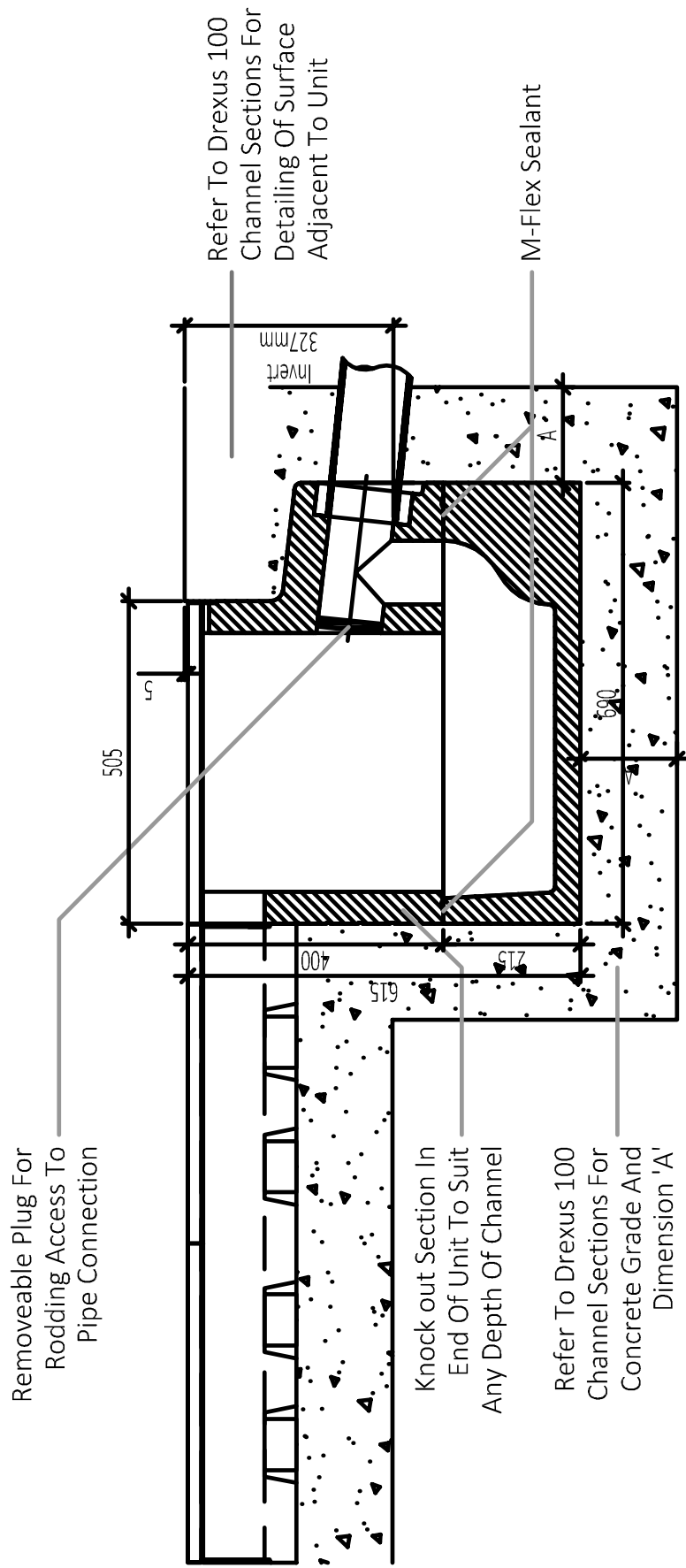

Drexus 100 - Inline End
Outfall

Standard Details

Drawing 3 of 3

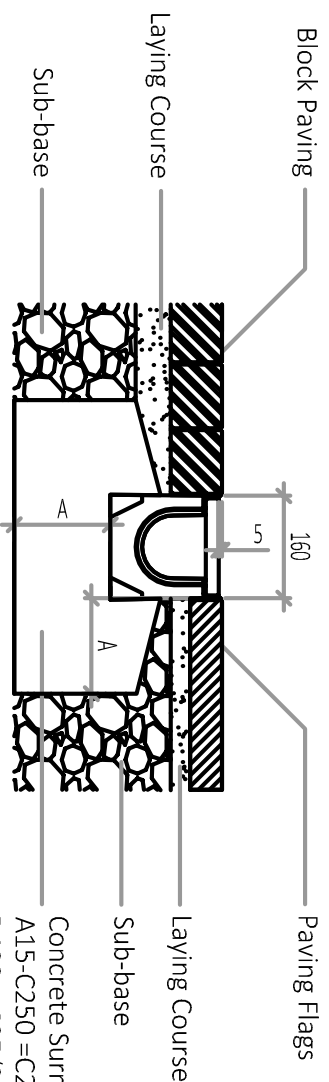

Concrete Surround
A15-C250 = C20/25
D400 = C25/30
*Concrete haunch to extend to surface for D400 applications

**Drexus 100 - Block paving/
Paving flags**
Loading class up to D400

A = 100mm (load class A&B)
A = 150mm (load class C&D)

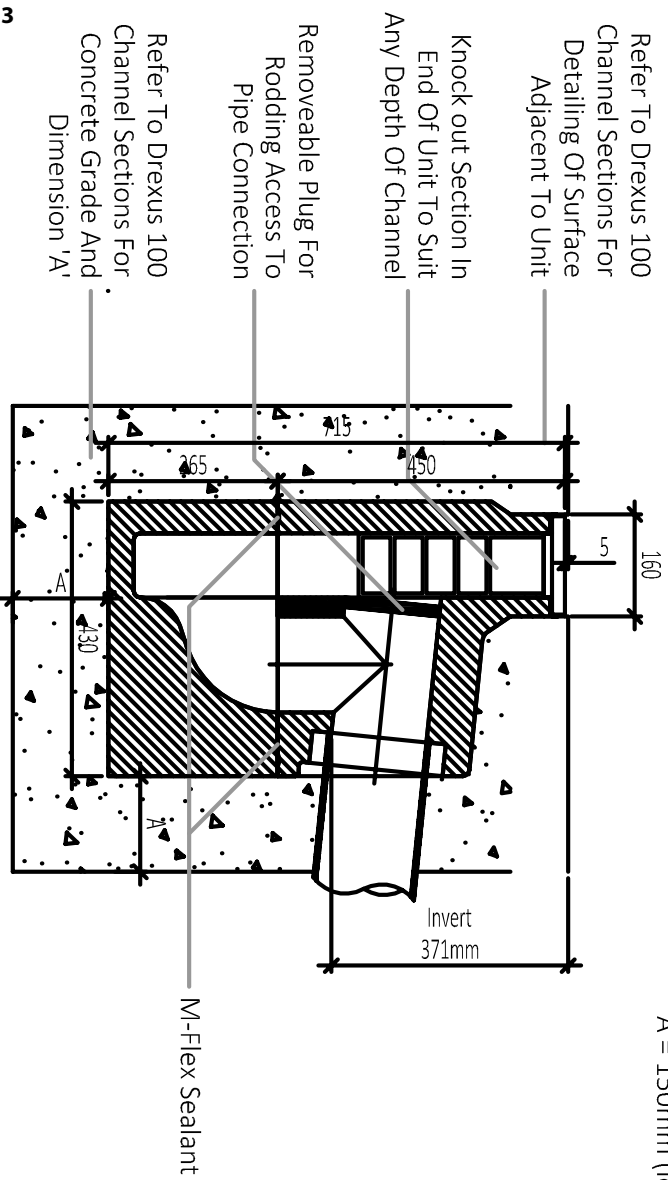

Refer To Drexus 100 Channel Sections For Detailing Of Surface Adjacent To Unit
Knock out Section In End Of Unit To Suit Any Depth Of Channel
Removeable Plug For Rodding Access To Pipe Connection
Refer To Drexus 100 Channel Sections For Concrete Grade And Dimension 'A'

**Drexus 100 - In-line Side
Outfall**

M-Flex Sealant

Standard Details

Notes for Drexus 100

Drawings 1 to 3

1. All dimensions are in millimetres.
2. All loading applications are as defined in BS EN 1433:2002 "Drainage Channels for Vehicular and Pedestrian Areas - classification, Design, Testing Requirements, and Evaluation of Conformity".
3. Outfall sections shall be jointed using Marshall's M-Flex sealant.
4. Vertical joints shall be jointed using Marshall's M-Flex sealant.
5. The concrete grade and dimensions for bed, haunch and surround are shown in the Drexus 100 section of the Design Guide.
6. Where the concrete surround is taken to the surface; the concrete should have the appropriate freeze thaw resistance.
7. For high loading applications with poor native ground conditions, consideration may be given to the local thickening of the sub-base.
8. Drexus 100 gratings should be chosen to suit the appropriate loading application, taking into account both static and dynamic loading conditions.
9. Movement joints details that fully isolate the Drexus 100 system whilst maintaining restraint shall be provided adjacent to all concrete slabs even when the slab is covered by another material. The use of dowel bars in concrete slab joints is common and should be considered especially for higher loading applications.
10. All grating bolts should be tightened to the appropriate torque shown in Drexus 100 section of the Design Guide.
11. The top surface of the grating shall be 5mm below the finished pavement level.
12. Mortar shall be Class 12 to BS EN 988-2:2003
13. The standard details show the general arrangements used by Marshalls for product evaluation and load test classification purposes. These may differ from customer requirements and site conditions and should be checked and accepted by the Engineer for project use.

Specification

Introduction

The following specification covers the complete Drexus 100 linear drainage system including ancillary fittings and is compatible with the standard detail drawings.

Drexus 100

1. The linear drainage system shall be Drexus 100 supplied by Marshalls plc. All channel materials and ancillary products detailed in this specification shall be supplied by Marshalls.
2. All components of the system shall be type tested and be fully compliant with the requirements of BS EN 1433:2002: Drainage channels for vehicular and pedestrian areas – Classification, design and testing requirements, marking and evaluation of conformity' when installed as per manufacturers recommendations.
3. The linear drainage system shall be Drexus 100 manufactured in pre-cast concrete, with the exception of certain fitments manufactured in steel or cast iron, as supplied by Marshalls in accordance with Standard Detail Sheets.
4. The linear drainage shall be a two part system consisting of **galvanised steel/cast iron gratings/covers** bolted to precast concrete drainage channels reference **(0/0; 5/0; 10/0; 15/0; 20/0)*** deep.
 - i. The gratings shall be bolted to the drainage channel with a minimum of **4 No. M12 stainless steel bolts per metre / one centrally located M12 stainless steel bolt fixed to a locking bar***.
 - ii. The drainage channel will have cast-in nominal 4mm thick galvanised steel edge angles.
 - iii. The system shall have a minimum of **refer to table*** mm²/m water inlet aperture area.
 - iv. The drainage channels shall have an invert width of 100 mm.
 - v. The overall width of the channel shall be 160 mm.
 - vi. The vertical channel surfaces and joints shall be made water tight using Marshall's M-Flex sealant.
6. The linear drainage system comprising gratings, covers, constant depth and transition channels, outfalls, T junctions channels, end caps, cap outlets, and sealants shall be installed to the line and levels indicated in the contract documents and in accordance with the manufacturer's instructions and Standard Details.
7. The drainage system shall be installed in accordance with manufacturers recommendations, industry best practice or **as detailed in the contract / WRc Sewers for Adoption; 7th Edition : 2012 / BS EN 752:2008 / BS 8000: Part 14:1989***

Note: * delete as required

Construction

Excavation

1. Sufficient material should be excavated to accommodate channel units, concrete bedding and haunching.
2. Any 'soft spots' or poorly compacted formation should be made good.

Setting Out

1. Setting out pins should be accurately located to the correct line and level with a string line level with the top rear corners of the channel units.
2. It may be advantageous to locate setting out pins to the rear of the units to avoid having to lift the units over the string line.

Outfalls

1. Drexus Outfalls should be installed first.
2. Sufficient material should be excavated to accommodate the trapped Drexus Gully.
3. 150mm of C25/30 mix (BS 8500-1&2) concrete of the appropriate mix is placed in the bottom of the excavation.
4. The bottom section of the two part Drexus Gully is lowered into position, with the appropriate pipe adaptor placed the aperture for connection to the underground pipework.
5. A suitable section of the wall of the outfall unit shall be cut out to allow adjacent drainage channels to abut without restricting the flow of water. Cutting shall be achieved by using a concrete saw or disc cutter.
6. Sufficient M-Flex sealant is gunned onto the top horizontal surface of the bottom section of the two part Drexus Gully so as to provide a seal between the top and bottom sections.
7. The top section of the two part Drexus Gully is lowered into position.
8. The bedding concrete should be laid and brought up to the appropriate level dependant on surface finish as shown in the Drexus 100 Standard Detail Sheet.

Channel Installation

1. Bedding concrete of the appropriate thickness and depth shall be laid as specified in the Drexus Standard Detail Sheets.
2. The top of the Drexus Channel shall be 5mm below the final pavement surface.
3. Channel Units shall be laid onto the freshly mixed bedding concrete, starting at the outfall, i.e. working uphill.
4. Alternatively, the Channel Units may be bedded on to a layer of 10 to 40mm cement mortar (M12 mortar to BS EN 998-2) on a previously prepared concrete foundation.
5. The concrete haunching shall be of a concrete grade appropriate to the Drainage Channel Loading Class as specified in the Drexus Standard Detail Sheets.
6. Haunching shall be carried out as one operation to a complete line of Channel Units, to the dimensions indicated in the Drexus Standard Detail.
7. Where channels are laid on or adjacent to existing or proposed concrete slabs, transverse joints shall be formed within the Units and haunching adjacent to the slab joints.
8. Longitudinal movement joints shall also be formed between the haunching and the slabs as described in the Drexus 100 Standard Detail Sheets.
9. Where cutting the Drexus Channel Units is required, they shall be cut with a concrete saw or disc cutter, so that no single Unit is less than 350mm long. Drexus gratings shall not be cut unless directed by the engineer.

Channel Joint Sealant

1. Jointing of adjacent channels shall be carried prior to fixing the gratings. Marshalls' M-Flex sealant should be gunned into the sealant groove formed when adjacent channels abut.
2. Surplus sealant shall be removed from the inner surface of the units as work proceeds.

Grating Installation

1. Adjacent Carriageway and/or footway construction shall not be commenced within 3 days of any jointing or haunching/surrounding concrete being placed.
2. Drexus gratings shall be securely bolted to Drexus Channel Units, before adjacent pavement construction is commenced.
3. All gratings shall be evenly spaced with bolts tightened down securely to the appropriate torque (25Nm).
4. On completion of the works, the drainage channel units shall be cleaned out and left free from obstruction. This shall be carried out either by removal of gratings or by high pressure water jetting (100-150 bar at 200 litres/min minimum). Unless otherwise agreed with the specifier, the slot openings shall be covered by timber boards or other method during jetting operations.
5. Outfall units shall be emptied.
6. The cleaning process should be repeated where necessary on completion of any remedial works.

Drexus End Caps/End Cap Outlets

1. Where the Drexus Channel run does not terminate at an outfall, the channel unit shall be sealed using the Drexus End Cap or End Cap Outlet.
2. These are to be held in position by installing 150mm of concrete haunching.
3. Marshalls M-Flex sealant should be gunned into the sealant groove.

In accordance with the Health and Safety at Work etc Act 1974, the Manual Handling Operation Regulations 1992 (as amended 2004) and the Construction (Design and Management) Regulations 2015, risk assessments should be carried out to protect workers from risks associated with musculoskeletal disorders and work related upper limb disorders.

This may require the use of lifting aids to assist installation.