



## Water Management



Water Management | Precast | Retaining Walls

# Welcome to Marshalls CPM

Marshalls CPM is a market leading manufacturer of concrete products with production facilities across the UK. This combined with a network of specialist distributors, enables us to provide our customers with complete coverage.

The Marshalls CPM business is built on a solid reputation for delivering quality products and providing a first class service with diversification and innovation a key to our strength. We supply a vast range of sustainable precast concrete products to every sector of the construction industry, fully supported by our experienced technical and engineering teams.

## Marshalls CPM – Sustainable Solutions

Concrete pipeline systems have a proven life of over 120 years in normal groundwater conditions, and demonstrate lower whole life cost savings, as well as installed cost savings, as in many circumstances, can be laid without a full granular bedding and surround. Concrete drainage pipeline systems are the most sustainable option available and a recent PAS2050 report by the British Precast Drainage Association and Carbon Clear demonstrated that a concrete pipe has up to 35% lower embodied carbon, compared to the same size HDPE pipe.

## Marshalls CPM – Quality and Assurance

Marshalls CPM manufacture a wide range of precast concrete products which are required by the customer to be of consistent high quality, designed and manufactured to British/European Standards and/or customer requirements and independently certificated (Kitemarked and CE marked where applicable. Only products covered by Harmonised Standards can be CE marked). They can be viewed at: <http://www.cpm-group.com/about/accreditations/>

To meet our objectives, the company applies a quality management system which has been developed in accordance with the requirements of ISO 9001 : 2015 certification.

## Marshalls CPM – Build on our strength

Concrete drainage products are strong and robust and the inherent strength of concrete means they gain strength over time. Marshalls CPM precast drainage products are manufactured to DC4, as detailed in BRE Special Digest 1: Precast Concrete in aggressive ground, and are proficient in withstanding the aggressive ground conditions found throughout the UK.

The Marshalls CPM team of engineers and technicians are at the forefront of precast concrete technology with BIM (Building Information Modelling), AutoCAD drawings, designs, calculations and installation advice being just some of the benefits we provide.

## Quality and Accreditation Marshalls CPM



Please note that all weights and dimensions are approximate and subject to change. A copy of Marshalls CPM's terms and conditions is available at [www.cpm-group.com](http://www.cpm-group.com)



## Marshalls CPM Partnerships

Marshalls CPM has built long term partnerships with both customers and suppliers alike, including major building and civil contractors, water companies and national merchant distributors. This enables us to manage our business more effectively and deliver quality precast products and services competitively.

We listen to our customers and work closely with them to provide solutions based on sound designs and engineering knowledge that we have acquired through years of pre-cast concrete production.

Marshalls CPM has developed partnerships with storm and foul water technology companies, ensuring that we offer the latest pre-fitted equipment and expertise in all forms of water management.



Pre-fitted Optimum Hydro-Brake®



The Perfect Manhole base



Ready Sump in association with T-T Pumps

## Marshalls CPM Continual Investment

To ensure that Marshalls CPM remains at the forefront of precast concrete drainage innovation, we have invested in state of the art machinery, moulds and equipment to ensure the very best in product design, manufacture and supply.



1800m sealed manhole being cored for a 900mm internal diameter pipe



Marshalls CPM has invested in the only 'rope' saw of its kind currently working in the UK, which can cut multiple pipes



Further investment into three factories has increased production capacity and quality

## **Quality**

Marshalls CPM precast concrete drainage products are manufactured in accordance with the Relevant BS EN 1916/7, BS 5911 and CE marked where applicable. Goods are certified by Quality Assessment under the Kitemark Scheme and ISO 9001 : 2015.

## **Sustainability**

Concrete pipeline systems are one of the most sustainable options available, they are manufactured from responsibly sourced materials, and can be made using recycled aggregates and cement replacements. Cement and aggregates have much shorter supply routes than many alternative products.

## **Proven Strength**

Concrete pipes manufactured by Marshalls CPM have a proven service life of over 120 years, it is not weakened by fire or moisture and do not lose their shape. They are resistant to DC4 and impacts such as jetting, so blockages can be cleared easily. As noted in a report by the House of Commons Select Committee on Environment, Transport and Regional Affairs in 1998, concrete pipes are not affected by rodent attack.

## **Installed Cost Savings**

Precast concrete pipes are rigid structural elements that do not always require a full granular surround, saving time in bedding and compaction. Excavated material can be reused and imported granular material can be reduced to a minimum. The reuse of excavated material during installation also reduces disposal costs - a key benefit when faced with continued increases in landfill tax. The number of vehicles needed are also reduced.

## **Durability**

Due to the inherent strength and durability of the Marshalls CPM precast concrete products, they are highly abrasion and corrosion resistant and don't lose strength over time.

## **Design Flexibility**

The Marshalls CPM precast concrete drainage products can be used for a number of purposes, including sewerage and sustainable urban drainage systems (SuDS) applications such as stormwater attenuation and storage.

## **Water Tightness**

Concrete pipes and manholes are designed to be watertight and are tested to pressure levels equivalent to a 5 metre head of water.

## **Fire Resistant**

Concrete is naturally fire resistant and is an effective barrier to the spread of fire. It does not produce smoke or emit any toxic fumes under fire conditions.

## **CDM**

Marshalls CPM is committed that its products are designed and manufactured to ensure the safety of users. Installation of products involves breaking ground and is thus considered as construction work under the Construction (Design and Management) Regulations 2015. Marshalls CPM puts a great deal of effort into ensuring that its designs are safe and will provide structural details to the Principal Designer nominated by the Construction Site Client (please contact Marshalls CPM's Technical Office).



# Product Index

---

<b>02-05</b>	<b>Welcome to Marshalls CPM / Product Index</b>
<b>06-07</b>	<b>Flexible Jointed Pipes / Perforated Pipes</b>
<b>08-09</b>	<b>Pipe Fittings / Ovoid Pipes</b>
<b>10-11</b>	<b>Dry Weather Flow Pipes / Pipe Bends</b>
<b>12-13</b>	<b>Tumbling Bay Junctions</b>
<b>14-19</b>	<b>Pipe Handling / Jointing / Air Testing</b>
<b>20-21</b>	<b>Traditional Manholes / Soakaway Chambers</b>
<b>22-23</b>	<b>Cover / Landing / Reducing Slabs</b>
<b>24-27</b>	<b>House Inspection Chambers / Caissons</b>
<b>28-31</b>	<b>Adjusting Units / Ladder System / Gully Pots</b>
<b>32-41</b>	<b>The Perfect Manhole System</b>
<b>42-45</b>	<b>Box Culverts</b>
<b>46-49</b>	<b>Head Walls / Catchpits</b>
<b>50-55</b>	<b>Preformed Manholes / Direct Access Pipe Systems</b>
<b>56-57</b>	<b>One Piece Chamber Systems / Large Sectional Wide Wall Chambers</b>
<b>58-60</b>	<b>Flow Control Chamber Systems</b>
<b>61-69</b>	<b>Bespoke Chamber Systems</b>
<b>70-75</b>	<b>T-T Pumping Stations</b>

# Flexible Jointed Pipes

Marshalls CPM offer an extensive range of precast concrete flexible spigot and socket jointed pipes that are manufactured and CE marked in accordance with the European Standard BS EN 1916 Class 120 and British Standard Kitemarked to BS 5911 for concrete pipes and ancillary products, for use in both foul and surface water applications.

All precast concrete pipes are manufactured to DC Class 4 BRE Special Digest 1.

Nominal Size	A	B	C	Angular Deflection	Joint Type			Approx Weight Of Pipe	Rocker Pipe Length	Butt Pipe Length
					'G'Ring	Integral	Lamell			
DN	mm	mm	mm	Degrees				kg	mm	mm
225	1250	380	335	2.90	●			155	600	600
300	1250	480	410	2.40		●		217	600	600
300	2500	497	410	2.40		●		420	600	600
375	2500	575	490	1.90		●		510	600	600
450	2500	675	575	1.60		●		705	600	600
525	2500	760	670	1.40		●		900	600	600
600	2500	850	770	1.20		●		1200	600	600
675	2500	980	820	1.05		●		1275	1000	1250
750	2500	1060	980	0.95		●		1924	1000	1250
825	2500	1131	1005	0.90		●		1820	1250	1250
900	2500	1235	1080	0.80		●		1920	1250	1250
1050	2500	1420	1260	0.70		●		2590	1250	1250
1200	2500	1590	1440	0.60		●		3550	1250	1250
1350	2500	1840	1620	0.53	●			4600	1250	1250
1500	2500	1810	1810	0.48			●	5230	1250	1250
1600	2500	1920	1920	0.44			●	5702	1250	1250
1800	2500	2160	2160	0.40			●	7150	1250	1250

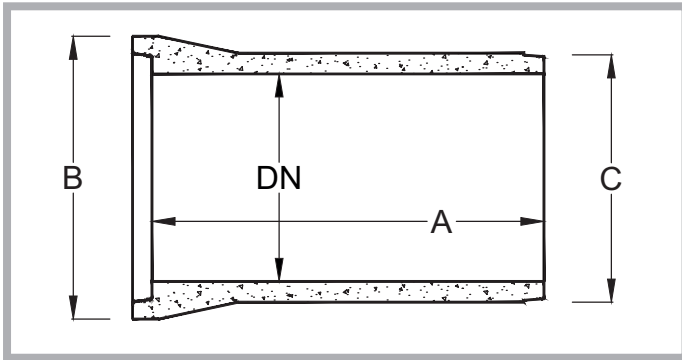
Recommended minimum chamber diameters to suit pipe diameters

Largest Pipe Diameter	Chamber Diameter mm
Less than 375	1200
375 - 450	1350
500 - 700	1500
750 - 900	1800
>900	Pipe DN + 900

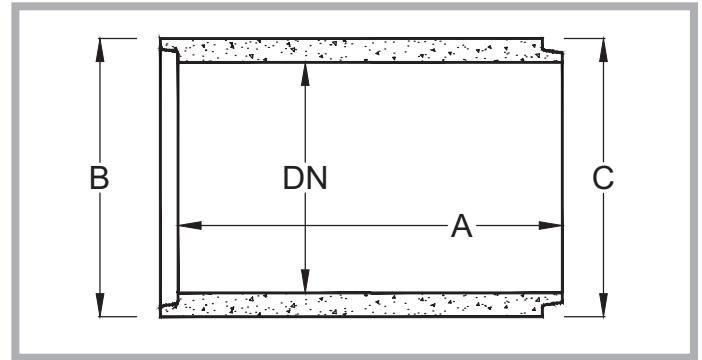


Table dimensions are for guidance only (as these may vary). For accurate dimensions and weights please contact the Technical team on 01902 356220 or [technical-cpm@marshalls.co.uk](mailto:technical-cpm@marshalls.co.uk)





**For DN 225 up to DN 1350**



**For DN 1500 up to DN 1800 / In-wall joint**

### Perforated Pipes

Marshalls CPM manufactures precast concrete perforated pipes up to 600mm diameter.

The pipes are drilled whilst wet and the semi-dry nature of the concrete used in the manufacturing process leads to spalling on the inner and outer surfaces around the holes. This is cosmetic only and does not affect the integrity of the pipes for land drainage use.



Perforated pipes comply with the Department of Transport Specification for Highway Works, which states the total area of drainage holes should not be less than 1000mm<sup>2</sup> per metre length of pipe.

### Note

1. Seals are normally SBR complying with BS EN 681-1. Other compounds such as Nitrile or EPDM can be supplied but may not be available from stock.
2. For details of the recommended Pipe Lifter for use in offloading, handling and installing pipes please visit [www.precastdrainage.co.uk/downloads](http://www.precastdrainage.co.uk/downloads)
3. Marshalls CPM Flexi-lift system for handling and jointing of pipes from 1200mm to 1800mm is available upon request.
4. Lorries with crane off load facilities are available for pipes up to 600mm upon request, site assistance is required on certain diameters.
5. When ordering pipes which may have to joint with pipes already on site or those previously laid, particularly extensions to contracts, it is important to advise the sales team in order to eradicate any jointing issues.
6. Marshalls CPM lubricant is advised for use on integral pipes, Marshalls CPM cannot guarantee that the jointing of concrete pipes with the use of other lubricants will be successful.

## Rocker Pipes / Butt Pipes

Butt pipes and rocker pipes allow for any differential settlement between the manhole and the pipeline, with the spigot/socket butt pipe being built into the manhole wall. A rocker pipe is then laid connecting the butt pipe to the incoming/outgoing pipe run, thereby incorporating a flexible joint close to the manhole.

### Rocker Pipe



Nominal Size	Effective Length
DN	mm
225 - 600	600
675 - 750	1000
825 and above	1250

### Spigot Butts



Nominal Size	Effective Length
DN	mm
225 - 600	600
675 - 750	1250
825 and above	1250

### Socket Butts



## Junctions

Branches of 100mm upwards can be fitted into all pipe sizes. Branches can be made from drainage materials other than concrete and are normally fitted to both full and short length pipes to suit customer requirements.

### Uni-Junctions

Marshall's CPM uni-junctions are 150mm diameter connections pre-installed on 300mm to 1800mm pipes. The uni-junction is an alternative to a fixed branch junction and offers the following advantages:

- Quicker and easier installation
- Less susceptible to site and transport damage
- Allows for more flexibility when positioning the branch along the pipeline
- Greater flexibility being able to accommodate a range of pipe material using adaptors
- Angular connections can be made using bends

The uni-junction is designed to suit 150mm supersleve clay pipes and not slimline clay pipes. To connect to plastic pipes an adaptor coupling from clay to plastic is required. Alternatively for certain plastic pipe an adaptor bush is available. For connection and compatibility details please refer to page 9 or call the Sales team on 01179 814500.





Uni-junction pipes should be laid and orientated so that the junction is made to one side of the pipe i.e. not from vertically above. Junctions are not designed for vertical surface compaction and need to be surrounded in concrete.

### Ovoid Flexible Jointed Pipes

Marshall's CPM offers a range of concrete ovoid pipes including a flexible joint seal for use with both foul and surface water applications. The ovoid concrete pipe is produced and tested in accordance with the relevant provisions of BS EN1916/BS5911-1 Class 150 including dimensional tolerances, crushing, hydrostatic, water absorption and joint tests.

### Benefits of Ovoid Pipes

- Lower operating costs, where some sewers may be laid without the need for pumping.
- Better self-cleansing and therefore less risk of siltation and blockage
- Reduced costs of trench excavation resulting from shallower gradients



Nominal Internal Size		Overall Length	Effective Length	Weight Per Pipe	Joint
width (mm)	height (mm)	(mm)	(mm)	(tonne)	
400	600	1350	1250	0.910	Sliding
600	900	2610	2500	2.170	Lamell
800	1200	2620	2500	3.300	Lamell

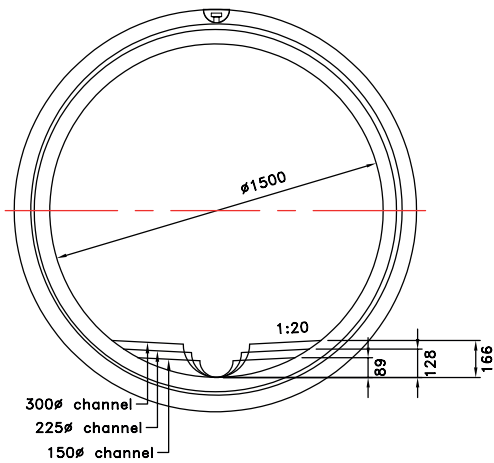
# Dry Weather Flow Pipes

Marshalls CPM has developed an Off-Site solution for the requirement of installing a dry-flow channel into concrete flexible jointed pipes.

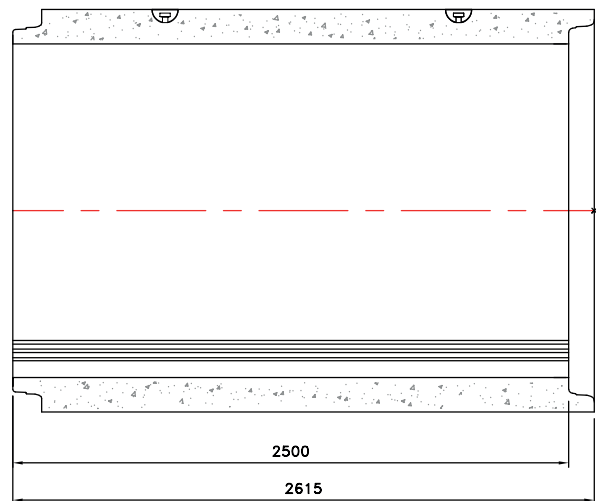
The machine made one-piece solution is available in 1500mm diameter with channel options of 150mm, 225mm and 300mm.

## Benefits of the system include:

- Removes the problem of confined space working.
- Considerable reduction in on-site construction time.
- Can reduce costs associated with in-situ construction by 50%.
- Can reduce over-pumping costs by 15%.
- Can be included as part of Off-Site Attenuation components.



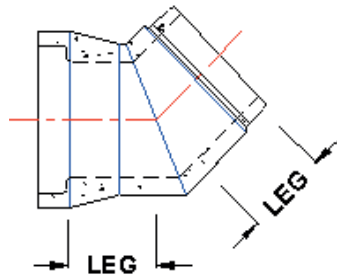
END ELEVATION



LONGITUDINAL SECTION



# Pipe Bends



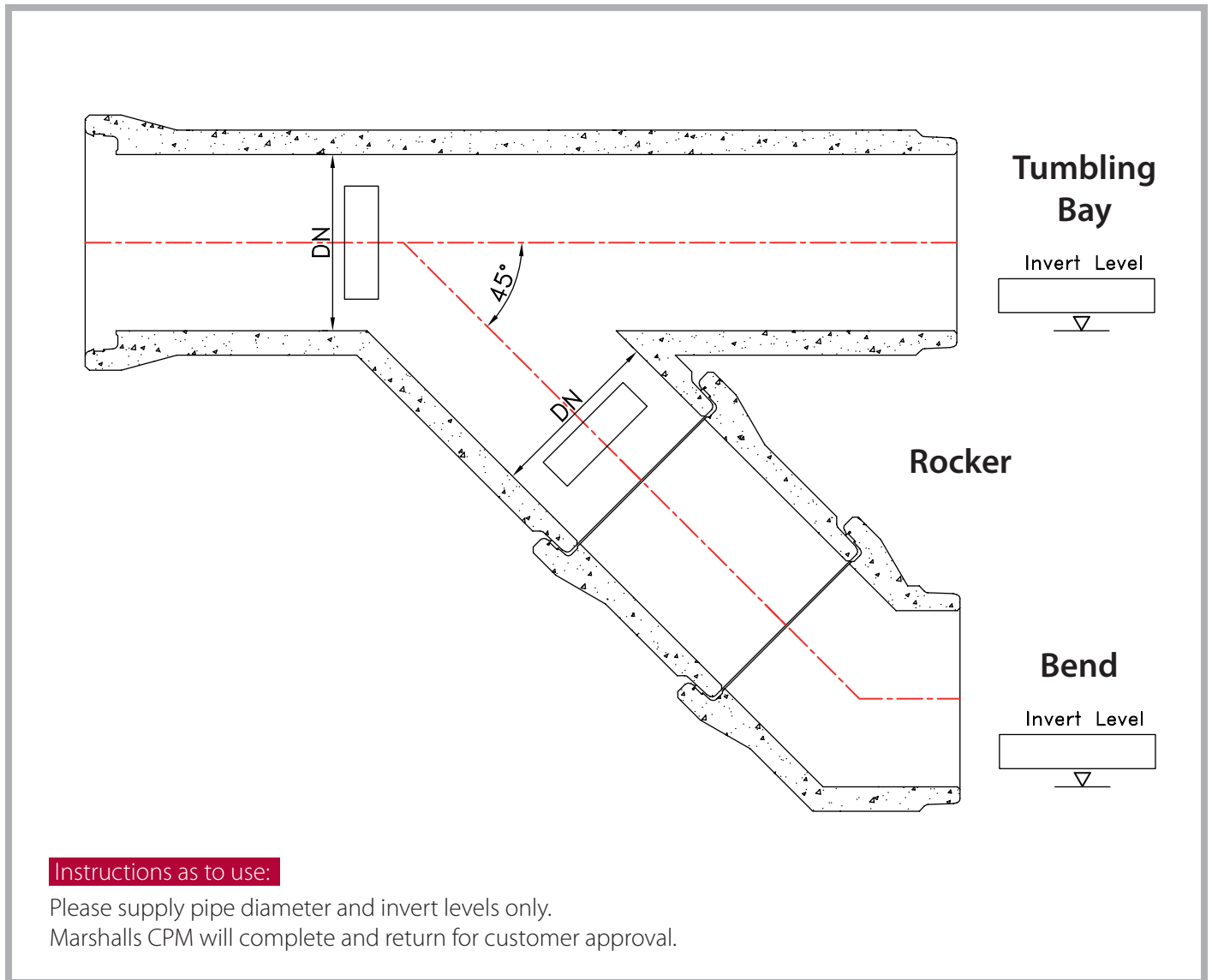
Precast concrete bends are manufactured by cutting pipes into two or three segments and joining them together at the required angle using an epoxy resin.

Nominal Size	11.25°		22.5°		45°	
	Leg	Total effective length	Leg	Total effective length	Leg	Total effective length
	mm	mm	mm	mm	mm	mm
225 - 600	300	600	300	600	300	600
675 - 750	500	1000	500	1000	500	1000
825 - 1200	625	1250	625	1250	625	1250
1350 - 1800	625	1250	625	1250	1250	2500

Nominal Size	90°	
	Leg	Total effective length
	mm	mm
225 - 300	415	1250
375 - 600	415	1250
675 - 900	585	1750
1000 - 1200	835	2500
1350 and above	Please contact the technical department on 01902 356220 or technical-cpm@marshalls.co.uk	

Where specific angles, centre line lengths or radii are required, these must be specified at the time of order (specials made to order). Bends may not necessarily have the same load-bearing capacity as the pipes with which they are to be laid. It is therefore recommended that they should be surrounded by suitably designed in-situ concrete where significant load conditions have to be met, or where anchorage of the pipeline is required. Bends have the same manufactured internal diameter and wall thickness as the pipes with which they are to be laid.

# Tumbling Bay / Oblique



**Instructions as to use:**

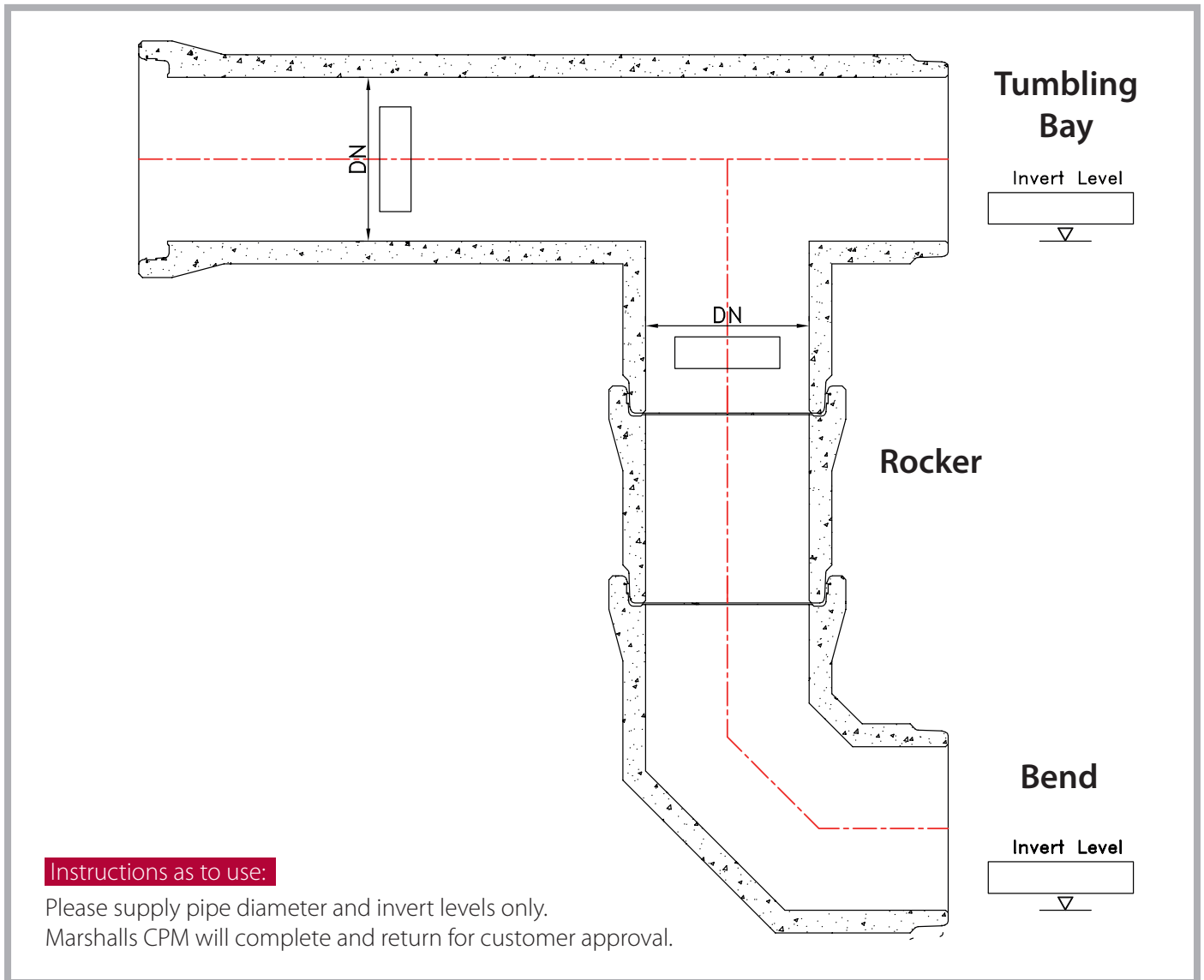
Please supply pipe diameter and invert levels only.  
Marshalls CPM will complete and return for customer approval.



All dimensions except diameter  $\pm 100\text{mm}$   
All bends are manufactured to  $\pm 4^\circ$  Tolerance

Please note: individual pieces (such as rockers and bends) need to be ordered individually as they do not come as a complete unit

# Tumbling Bay / Square



All dimensions except diameter  $\pm 100\text{mm}$   
All bends are manufactured to  $\pm 4^\circ$  Tolerance

Please note: individual pieces (such as rockers and bends) need to be ordered individually as they do not come as a complete unit

Convey Control Store Treat Release



## Pipe Handling and Jointing

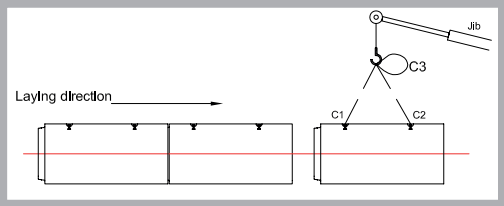
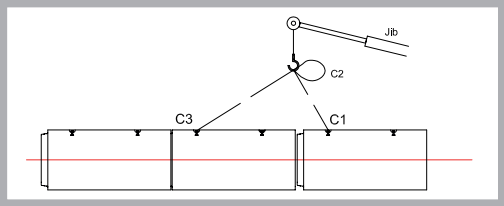
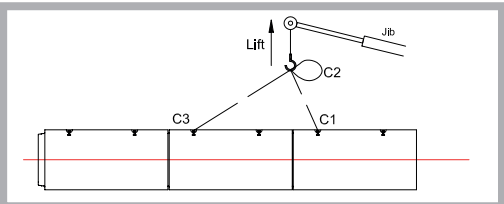
Marshalls CPM recommends that prior to laying the pipeline all products and equipment are checked to ensure that they are in good working order.

1. Avoid damage when handling, especially to the ends of the concrete pipes and never drag or roll pipes over rough ground.
2. Use the correct crane for offloading, utilising canvas/fabric slings with central lift or if ordered, large diameter pipes incorporate lift pins where Marshalls CPM head link and chain set can be used.
3. Pipes should be handled individually using a properly designed 'C' hook, beam sling or other purpose-designed system. Small diameter pipes may be slung through in order to avoid damage to jointing surfaces and consequent leakage of the laid pipe.
4. Pipe lifters are available that are designed to improved site safety and speed up installation. The pipe lifter removes the need for operatives to climb on the back of vehicles, eliminating working at height during the off-loading of deliveries. Please visit: [www.precastdrainage.co.uk](http://www.precastdrainage.co.uk) for more details, or call our Sales team on 01179 814500 or alternatively email: [salesemail@marshalls.co.uk](mailto:salesemail@marshalls.co.uk)
5. Joint rings (when supplied loose) must be stored away from sunlight, heat or possible contact with any oils.
6. Stack pipes on even ground on timbers to protect the joints, making sure the bottom row is securely chocked.

For more information please download the installation guide at: <http://www.cpm-group.com/products/drainage/concrete-pipes/>

### For larger pipes use of 'Flexi-lift' lifting/jointing chains

For 1200mm pipes and above, plus larger size ovoid pipes, Marshalls CPM recommends the use of the 'Flexi-lift' lifting system where special lifting anchors can be cast into the concrete pipes at manufacture.

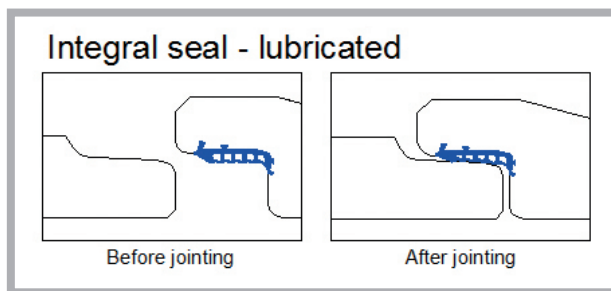
1.  1. Use the equal length chains C1 and C2 for lifting and placing each pipe in the trench.
2.  2. Connect the longer length chain, C3, to the pipe already laid and place the shorter length chain, C2 on the hook provided.
3.  3. The pipe can then be jointed without moving the jib of the crane.

### Joining of integral seal joints (seals cast into pipe during manufacture)

1. Lubricant should be applied to the spigot end of the pipe, ensuring the radius area and entire length of the spigot is covered. Additional lubricant may also be applied to the seal face to assist jointing.
2. Enter the spigot carefully into the socket and ensure that the pipes are correctly aligned.

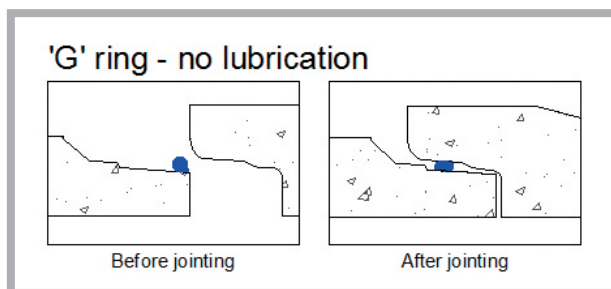
Marshalls CPM integral pipes should only be jointed using a Marshalls CPM approved lubricant which is available from our Sales team on 01179 814500 or email [salesemail@marshalls.co.uk](mailto:salesemail@marshalls.co.uk)

Marshalls CPM cannot guarantee that the jointing of concrete pipes with the use of other lubricants will be successful.



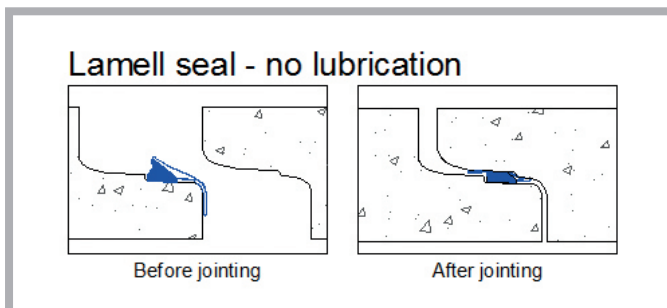
### For rolling ring joints ('G' ring)

1. Stretch and position the seal onto the spigot of the pipe and ensure it is not twisted. Even out the stretch by lifting and releasing at several points around the spigot.
2. Offer the pipe spigot to the socket, but keep clear of engagement by 25mm so that the joint ring is not disturbed.
3. Enter the spigot carefully into the socket ensuring that the seal is correctly positioned and that the pipes are correctly aligned.
4. Under no circumstances should the joint be lubricated.
5. Ensure that pipe bedding material does not enter the joint at any time.



## Lamell Joints

1. Correctly position and bed the first pipe. Prepare the bedding for the second pipe and hollow out for incoming spigot to prevent bedding material entering the joint.
2. Check the spigot profile for cleanliness and that the seal is the correct size. Place the seal on the spigot with the small step on the underside.
3. It is important that the seal is placed squarely back against the shoulder on the spigot and that the stretch is even around the joint. This is achieved by lifting and releasing the seal at opposite quarter points on the circumference.
4. Ensure that the socket of the previous pipe is wiped free of dirt and grit and reasonably dry. Under no circumstances should the joint be lubricated. Enter the spigot checking that the pipes are correctly aligned.
5. The joint may now be closed whilst the pipe is still being supported by the crane.

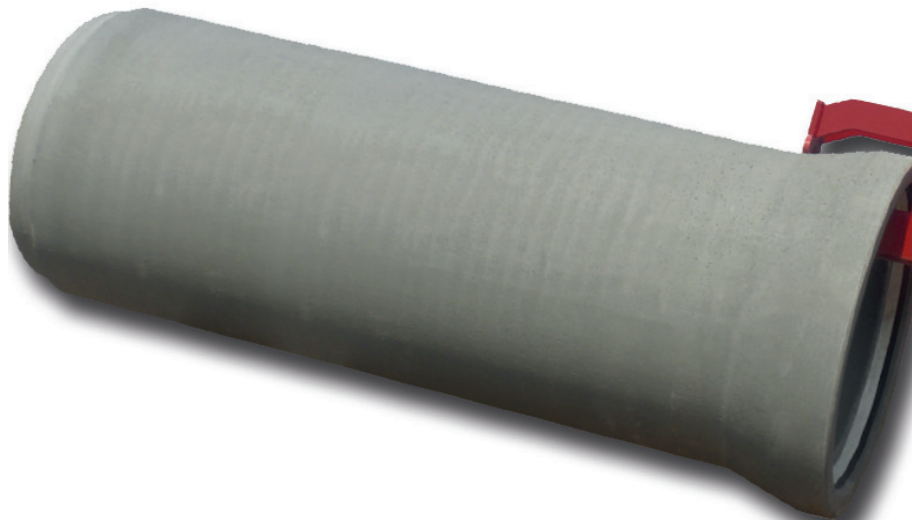


## All Pipes

Check and pack (if necessary) the bedding material underneath the pipe barrel, an internal gap of between 10-25mm should be obtained upon completion of jointing.

# Lifting and Jointing of Pipes

---



## Concrete Pipes / Lower the Risks / Lower the Costs!

- **Safer. No operative needed on vehicle during offloading or in trench during installation.**
- **Easier. Simple to use. No special equipment and minimal training required.**
- **Faster. Around 50% saving in installation time.**
- **Cheaper. Fewer operatives plus greater productivity.**

The Pipe Lifter makes light work of the installation of waste water pipelines. Simply attach it to your excavator in seconds, using a quick-hitch coupling. There are no hydraulic links or additional energy requirements.

There is no need for anyone to stand on the bed of the vehicle during offloading (the biggest cause of accidents during pipe laying). There's no need for anyone to stand in the trench during installation. And there are no slings or chains to trap hands and fingers. The whole operation is around 50% faster. And you can reduce the size of your installation gang, so costs are lower too. The Pipe Lifter is suitable for standard UK specification BS EN1916 concrete pipes from DN 300 to DN 1200. A Type 2 Pipe Lifter has also been introduced for larger concrete pipes DN1350 to DN2000.

To buy or rent the Pipe Lifter please call:

MGF Tel: 01942 402700 or visit [www.mgf.ltd.uk](http://www.mgf.ltd.uk)

Probst Tel: 01939 235325 or visit [www.probst-handling.co.uk](http://www.probst-handling.co.uk)

Klepp Mek AS Tel: +47(0)51 788751 or visit [www.kleppmek.no](http://www.kleppmek.no)



## Air Testing

The air test is not covered by the European Standard, but a pipe which complies with the standard will usually comply with the air test. Failure to pass the air test will not normally preclude the acceptance of the pipeline if a successful water test can be achieved.

Ensure the test equipment is in good condition.

Inflatable stoppers are recommended for ease of use.

The test should be carried out after every 3 or 4 correctly laid and jointed pipes prior to commencement of backfill.

A successful test is achieved if the equipment shows a fall in pressure of no more than 25mm after 5 minutes, having allowed a suitable period for stabilisation.

If the pressure falls sharply and the pipes appear to have failed, the following checks must be made before contacting Marshalls CPM for assistance:

- (a) Check the test equipment is in good condition
- (b) Check if the stoppers are leaking - use industrial soap around the edge of the stopper to provide an effective seal if necessary
- (c) Check the joint rings are correctly located

Dramatic temperature changes both inside and outside of the pipe could affect the air test. Reference should be made to BS EN 752.

If after following this guidance you still have problems with our product, please contact the supplying works in the first instance, on the following telephone numbers.

■ Mells	01179 814500
■ Pollington	01405 860591
■ Newmains	01698 386922
■ Technical	01902 356220

Marshalls CPM regrets that failure to follow the advice given may result in any subsequent claims being invalid or in a call out charge being made if Marshalls CPM technical personnel have to attend on site.



Convey Control Store Treat Release



# Traditional Manholes / Soakaway Chambers

Marshalls CPM precast concrete chamber rings are manufactured with tongue and groove joints and comply to BS EN 1917 BS 5911-3 and are supplied with three nominal 50mm diameter holes for lifting purposes.

DN	Depth Available				Wall Thickness	Outside Diameter	Approx Weight p/m depth	Soakaway Holes p/m depth
	250mm	500mm	750mm	1000mm				
mm					mm	mm	kgs	Number
900	●	●	●	●	70	1040	530	12
1050	●	●	●	●	80	1210	710	16
1200	●	●	●	●	90	1380	912	16
1350		●	●	●	95	1540	1080	16
1500		●	●	●	105	1710	1330	20
1800		●	●	●	115	2030	1760	24
2100		●	●	●	125	2350	2140	24
2400		●	●	●	140	2680	2740	28
2700		●	●	●	150	3000	3400	32
3000		●	●	●	165	3330	4140	36
3660+			●	●	185	4030	5300	44
4000+			●	●	200	4400	6360	48

+ 3660mm and 4000mm are not covered by the British Standard, but comply with all the relevant provisions of BS EN 1917/5911-3. 3660 and 4000mm units are supplied in two halves.

Standard chamber rings can be perforated with 75mm holes for use as soakaways, providing a minimum area of exfiltration of 50,000mm<sup>2</sup> per meter nominal diameter per meter of depth.

## Chamber sections can be supplied with:

- Fixed double steps or integrated ladder system
- Holes, cut-outs or bases cast-in
- Marshalls CPM strip and primer

## Safety Notice:

For safety reasons, all chamber sections are loaded and delivered chimney fashion. When offloaded, they should never be stored on their side (on the roll), but should always be laid flat. Offloading facilities are available upon request up to 3000mm. Suitable lifting bolts for offloading and handling purposes can be purchased from Marshalls CPM. All lifting equipment comes with the appropriate test certificates. Please call 01179 814500 and speak to a member of the Sales team or email [salesemail@marshalls.co.uk](mailto:salesemail@marshalls.co.uk)





## Rectangular Manholes

Rectangular manhole units have a tongue and groove joint and are manufactured and tested in accordance with BS EN1917 / BS5911-3

These units comply with the recommendations in the Water Services Association publication Sewers for Adoption, where the manhole from ground level to the soffit of the pipes is less than 1.50m in light or main road situations.

Manhole Section	Internal Dimensions (mm)	External Dimensions (mm)	Depth mm	Approx Weight (kg)	Palletisation		
					No. Per Pallet	Approx Weight (kg)	Banded Pack Size
Cover (heavy duty)	1200 x 675 access	1510 x 1060	125	239	5	1195	
Cover (heavy duty)	600 x 600 access	1380 x 930	150	300	5	1800	
Cover (light duty)	600 x 600 access	1366 x 916	90	180	5	750	
Chamber	1200 x 750	1350 x 900	150	115	8	920	8
Chamber	1200 x 750	1350 x 900	225	173	5	865	5

Note: For rectangular manholes use 12mm x 60mm sealant (4.2m).

## Marshalls CPM Strip and Primer

Sealant Size	12mm x 60mm		12mm x 80mm				12mm x 120mm				12 x 75mm	12 x 25mm
	900	1050	1200	1350	1500	1800	2100	2400	2700	3000	3660 / 4000	3660 / 4000
Chamber DN (mm)	900	1050	1200	1350	1500	1800	2100	2400	2700	3000	3660 / 4000	3660 / 4000
Sealant length (per joint)	3.5m	4.0m	4.5m	5.0m	5.5m	6.5m	7.5m	8.5m	9.5m	10.5m	13.5m / 16.5m	2.5m
Primer	5 Litres / 100m		5 Litres / 75m				5 Litres / 50m				None required	





## Cover Slabs

Marshalls CPM offer a range of standard heavy duty cover slabs from DN900 to DN3000 to BS EN 1917 / BS 5911-3 and DN3660 to DN4000 to Eurocodes BS EN 1991 1 and 2 as well as a wide range of standard specials which are outside the British and European standard but are regularly used throughout the industry as well as a bespoke range of 'one offs' that require that "extra special something".



Chamber DN	Maximum Thickness	Overall DN	Standard Access Sizes (mm)					Weight 675 <sup>2</sup> access
			600 x 600	675 x 675	750 x 750	750 x 600	1200 x 675	
900	150	1230	C	C	X	X	X	235
1050	150	1230	E	E	C	E	X	235
1200	150	1400	E	E	To order*	E	X	356
1350	150	1560	E	E	To order*	E	C	503
1500	170	1730	E	E	To order*	E	C	890
1800	175	2050	E	E	To order*	E	E	1208
2100	178	2370	E	E	To order*	E	E	1745
2400	178	2700	E	E	To order*	E	E	2200
2700	205	3020	E	E	To order*	E	E	3380
3000	225	3350	E	E	To order*	E	E	4300
3660	300	3960	E	E	To order*	To order*	To order*	8800
4000	300	4500	E	E	To order*	To order*	To order*	11400

\*Made to order / E=Eccentric / C=Central

### Notes

1. Access are 150mm from inside of chamber wall position (unless otherwise stated).
2. 3660mm and 4000mm cover slabs are supplied in two sections and not kitemarked.
3. All accesses have 75 x 75 corner chamfers.
4. All cover slabs are 'heavy duty' and are suitable for use in main roads.
5. 1050mm cover slab 750 x 750 central opening is 1400 OD.
6. 1350mm cover slab 1200 x 675 central opening is 1730 OD.

## Landing Slabs



Landing slabs to suit DN1500 chamber sections and above are manufactured with a 900mm circular access.

## Reducing Slabs



Reducing slabs to suit up to and including DN4000 chamber sections are generally manufactured with a 900mm, 1050mm or 1200mm circular reducing section.

Reducing slabs are generally manufactured with a built in ring.

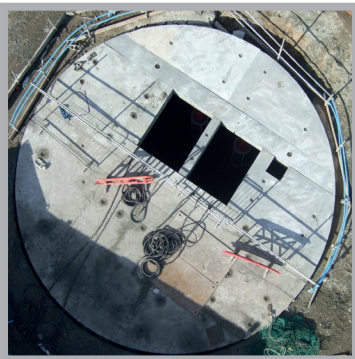


## Special Cover Slabs

As demand for high loading and multi access cover slabs has risen, Marshalls CPM has become experts in both the design and manufacture, producing a wide range of bespoke cover slabs that can be manufactured to customer's specifications.

Typical examples of special cover slabs supplied are:

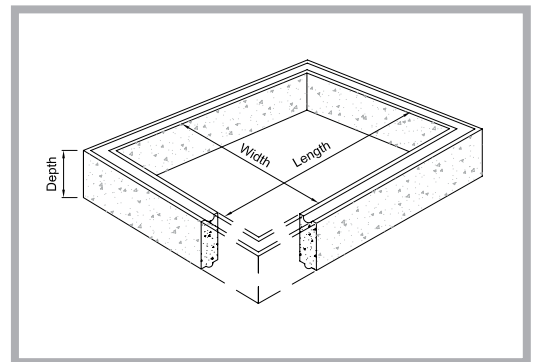
- For pumping stations and incorporating davits and/or rebates
- Extra heavy duty slabs for airports and ports
- Extra-large accesses
- Slabs designed to comply with Highways Agency Specifications
- Multiple accesses
- Non-circular slabs
- Slabs with customers own reinforcement design



# House Inspection Chambers

## House Inspection Chambers

House Inspection chambers are easily handled and excavation below ground level is kept to a minimum. The Marshalls CPM range of precast concrete inspection chambers are available in a variety of depths and are manufactured to BS EN 1917 / BS 5911-4.



Internal Dimensions (mm)	Depth of Sections (mm)	Wall Thickness (mm)	Weight of Sections (kg)	Pallets	
				No. Per Pallet	Approx Weight (kg)
600 x 450	150	50	44	32	1410
600 x 450	225	50	58	20	1160
600 x 450	300	50	86	16	1380
750 X 600	150	60	67	16	1070
750 X 600	225	60	100	10	1000
750 X 600	300	60	134	8	1070
1000 X 675	150	65	83	16	1330
1000 X 675	225	65	130	10	1300

For depths in excess of 1.5m the use of a concrete surround is recommended.

## Top sections complete with concrete covers weights and dimensions

To suit chamber sections (mm)	Dimensions (mm)	Effective depth (mm)	Overall depth (mm)	Weight of sections (kg)	Palletisation	
A x B	C x D	E	F	kg	No. Per Pallet	Weight (kg)
600 x 450	845 x 680	120	120	46	10	1010
750 x 600	865 x 715	120	120	67	10	1220
1000 x 675	1150 x 825	160	170	190	N/A	N/A

## Top sections for metal cover and frame weights and dimensions

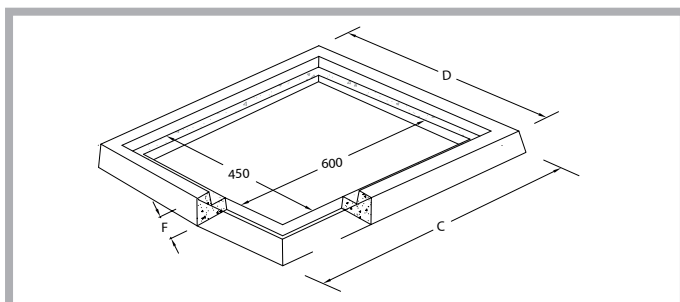
To suit chamber sections (mm)	Overall Dimensions (mm)	Effective depth of sections (mm)	Overall depth of sections (mm)	Weight of sections (kg)	Palletisation	
A x B	A x B	E	F	kg	No. Per Pallet	Weight (kg)
600 x 450	825 x 675	60	85	42	10	420
750 x 600	870 x 720	50	60	44	10	440
1000 x 675	1150 x 825	50	60	89	10	890

Top sections for 750mm x 600mm and larger chambers act as reducing slabs, enabling standard 600mm x 450mm covers to be fitted irrespective of the size of chambers involved. Covers and reducing slabs are for domestic loading situations only.

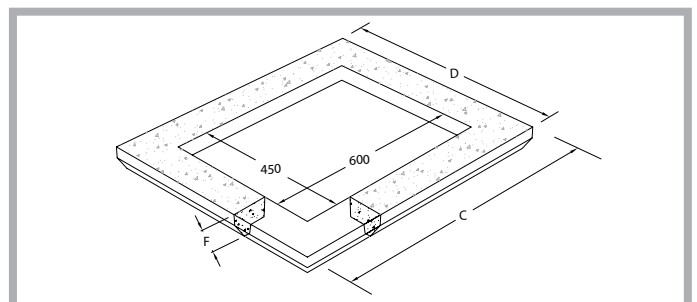
To provide concrete top section for 1000mm x 675mm requires:

1. Top section for metal cover and frame 1000mm x 675mm (i.e. reducer).
2. Top section for concrete cover 600mm x 450mm and concrete cover slab.

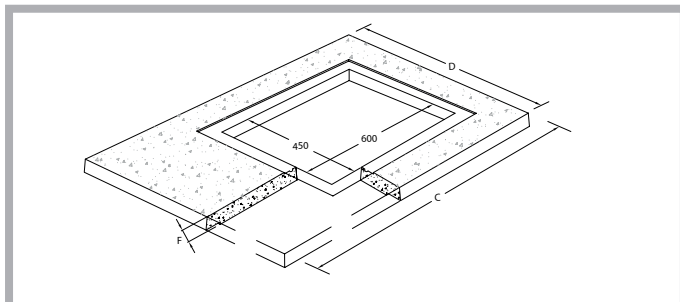
Concrete cover slabs are supplied to suit the top sections and are 695mm x 540mm overall, 60mm thick and weigh 55 kg.



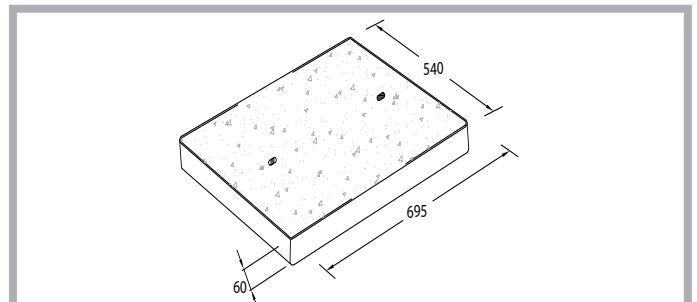
600mm x 450mm top section for concrete cover



600mm x 450mm top section for metal cover



1000mm x 675mm top section for metal cover/reducing slab



600mm x 450mm concrete cover slab



# Caissons

Marshalls CPM offer a range of reinforced precast concrete manhole units specially designed for sinking by the caisson method from 2000mm diameter to 4000mm internal diameter in varying depths. (Please see table)

This is achieved by using a shaft sinking system and is made in accordance to BS EN 1917 and kitemarked where relevant to BS 5911-3.



## Advantages of the system include:

- Suited to weak soils, high-plasticity clays, silts, sands and gravel
- Minimal site labour costs
- Quick and easy to install
- Fast, clean accurate construction
- Immediate permanent shafts
- Suitable for jacking pits

The caisson shaft sinking system was originally designed for use in microtunnelling, but is now more widely used for construction of pumping stations, wet wells and manholes, particularly in difficult ground conditions.

## Notes

1. 3660mm and 4000mm chambers are supplied in two sections for assembly on site.
2. The steel cutting shoes provide a 10mm overbreak on all except 3660mm and 4000mm which provide a 20mm overbreak.
3. Cutting shoes with a larger overbreak can be manufactured upon request.
4. Caisson lifting equipment is available for purchase from Marshalls CPM on 01179 814500 or [salesemail@marshalls.co.uk](mailto:salesemail@marshalls.co.uk)
5. Reference is strongly recommended to the Caisson Installation Guide available at [www.cpm-group.com](http://www.cpm-group.com) as non-compliance may result in installation problems for which Marshalls CPM can accept no responsibility.

# Caisson Chamber Sections

DN	Wall thickness	Outside diameter	Effective depth	Overall depth	Weight per unit	Jointing plates
mm	mm	mm	mm	mm	kg	No.
2000+	130	2260	500	500	1065	3
2000+	130	2260	750	750	1598	3
2000+	130	2260	1000	1000	2130	3
2400	140	2680	500	522	1370	3
2400	140	2680	750	772	2055	3
2400	140	2680	1000	1022	2740	3
2740+	160	3060	500	500	1790	6
2740+	160	3060	750	750	2685	6
2740+	160	3060	1000	1000	3580	6
3000	175	3350	500	500	2135	6
3000	175	3350	750	750	3203	6
3000	175	3350	1000	1000	4270	6
3660+	185	4030	750	769	3980	6
3660+	185	4030	1000	1019	5300	6
4000+	200	4400	750	769	4770	6
4000+	200	4400	1000	1019	6360	6

+Non Kitemarked

## Caisson Cover Slabs

DN	Effective thickness	Overall thickness	Overall diameter	Approx weight (675 <sup>2</sup> ) Access
mm	mm	mm	mm	kg
2000	185	200	2370	1690
2400	163	178	2700	2200
2740	185	200	3060	3170
3000	200	225	3350	4300
3660+	290	300	3960	8800
4000+	290	300	4500	11400

3660mm and 4000mm cover slabs are supplied in two halves

+Non Kitemarked

# Manhole / Integrated Ladder System

Marshalls CPM, in conjunction with Caswick, the market leading manhole step producer has developed an Integrated Manhole Ladder system. This innovative product has been designed to provide safe access and egress to precast concrete manholes, caisson shafts and inspection chambers. A range of rungs are pre-fitted into the chamber to make the installation of the ladder quick, cost effective, reliable and safer than conventional ladders.

The system has WRc approval and meets the essential requirements of existing and new design codes in terms of dimensions and performance.



## System advantages

- The integrated manhole ladder system has the innovative ladder rungs pre-fitted into the chamber rings therefore the system is delivered to site partly pre-installed
- The chamber rings are then installed in the conventional way, ensuring that the ladder steps are inline
- The Integrated Manhole Ladder System has been granted WRc approval

## Ease of Installation

- The Ladder Rungs are pre-fitted at 250mm centres into the chamber sections, leaving only the Stringer, Locating Bracket and End Caps to fit
- Minimal access to a confined space to fit ladder stringers
- No lifting, drilling or temporary access required to chamber

## Flexibility

- The incorporation of the Ladder Rung in the manhole automatically takes account of the variation in depth to design
- No bespoke ladder needs to be surveyed, ordered or manufactured
- No equipment hire compared to fitting traditional galvanised steel ladder

## Safety

- The polypropylene polymer encapsulation gives high visibility and no sharp edges
- The rung has a tread pattern to give good slip resistance
- The stringer has a circular cross section designed to give a secure hand grip unlike a conventional ladder which is normally too large to safely hold on to

## Quality

- Ladder rungs are kitemarked to BS EN 13101
- Ladder rungs are reinforced with high tensile steel tube
- The ancillary fitting brackets are made from stainless steel Grade 304 or 316

## Durability and Strength

- Ladder rungs are pre-fitted to ensure factory controlled performance and are pull out and deflection tested to BS5911 part 3
- The chemical resistance of polypropylene can be considered equivalent to Grade 316 stainless steel

## Product Standards

- The system has been designed and manufactured in accordance with the requirements specified in: BS EN 13101 Steps for underground man entry chambers / BS EN 14396 Fixed ladders for manholes

# Adjusting Units / Seating Rings / Corbel Slabs

## One piece cover frame adjusting units

Cover frame adjusting units are reinforced 65mm deep units which can be used in place of engineering bricks to adjust the ductile or cast iron covers and frames to the required level and are kitemarked to BS EN 1917 / BS EN 5911-3

The use of adjusting units is specified in 'Sewers for Adoption'.

### Advantages Include

- Quick and easy to install using semi-skilled labour
- Fewer joints which reduce likelihood of infiltration
- All concrete units can be ordered from one source
- There is less risk of on site damage or pilferage



Access Size (mm)	Access Position	External Dimensions (mm)	Depth (mm)	Weight kg
600 x 600	Central	1000 x 950	65	70
675 x 675	Central	1000 x 950	65	60
750 x 600	Central	1030 x 900	65	75
*600 x 600	Eccentric	1000 x 860	65	80
750 x 750	Central	1000 x 1000	65	80

\*600 x 600 Eccentric/ Corbel units have an eccentric opening which is used in conjunction with a 750 x 600 cover slab opening.



## Two piece cover frame adjusting units

Access Size (mm)	Access Position	External Dimensions (mm)	Depth (mm)	Weight kg
600 x 600	Central	860 x 860	65	48
675 x 675	Central	935 x 935	65	65
1200 x 675	Central	1400 x 950	65	78



## Scottish Water seating slab (Lothian Slab)

Access Size (mm)	Access Position	External Dimensions (mm)	Depth (mm)	Weight kg
600 x 600	Central	1125 x 1125	150	269
675 x 675	Central	1125 x 1125	150	236
750 x 600	Central	1125 x 1125	150	236
750 x 750	Central	1125 x 1125	150	196

### Disclaimer:

It is the customers responsibility to check that the proposed cover and frame flange is fully supported by the chosen adjusting system as flange sizes vary between manufacturers.

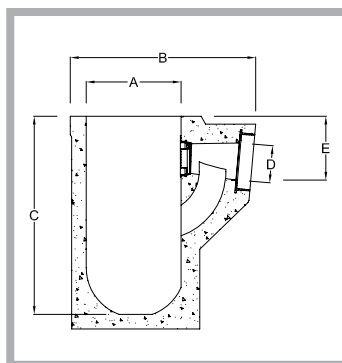
# Gully Pots

Marshalls CPM gullies are typically used in highways and parking areas and are produced monolithically on fully automated machines, providing a strong robust unit that needs no concrete surround and are not subject to floatation.

Marshalls CPM Gullies are manufactured to BS5911-6

Precast concrete road gullies can be supplied with adaptors for connection to clay or plastic pipes.

Marshalls CPM gullies are delivered inverted and should be offloaded, turned and handled using a webbing strap in choker fashion.



## Gully weights and dimensions

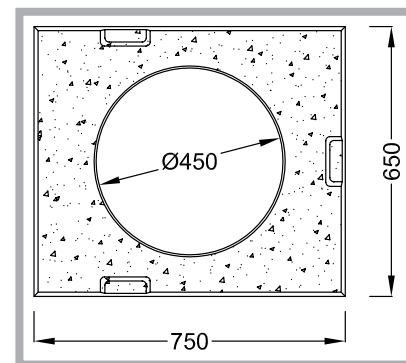
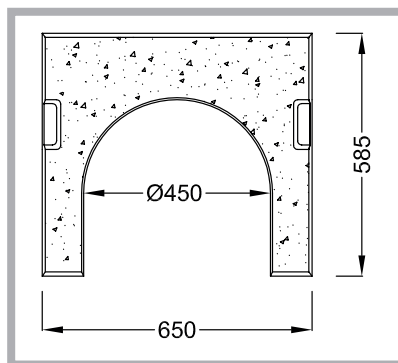
DN	Nominal wall thickness	Width mm	Effective depth mm	Capacity	Approximate measurement mm	Outlet i/dia mm	Weight per unit	No. per full 23.5 tonne load
A	mm	B	C	Litres	E	D	kg	No
375	55	698	750	50	250	150	188	125
375	55	698	900	69	250	150	216	108
450	55	780	750	70	250	150	260	90
450	55	780	900	95	250	150	290	80
450	55	780	1050	120	250	150	320	73

## Gully cover slabs

Gully cover slabs are available in both square and 'U' shaped, with handling recesses for lifting brackets and are designed as a seating for a gully grate and used on top of a 450mm gully. Marshalls CPM gully cover slabs are quick to lay and sit flush to the kerb for enhanced stability, eliminating brickwork joint 'weakspots'.

Slab	Dimensions (100mm thick)	Kg (100mm thick)
Square	750 X 650	80
U	585 X 650	50

A 65mm thick version is also available.





## Gully Adaptors

The gully adaptor is a versatile elastomeric sealing adaptor ring manufactured in EPDM rubber to BS 2494 Type D. This table shows the tolerant of a range of pipe diameters and profiles - for use only with Marshalls CPM kitemarked concrete gullies.

To Suit Pipe	Type of Pipe	
DN		
160	uPVC pipe to BS4660	plastic
150	aquapipe - corrugated	plastic
150	ultrarib	plastic
150	twin wall PVC - corrugated	plastic
150	supersleve	clay
150	densleeve	clay
150	hepseal	clay

### Procedure for installation and selection of gully adaptor

1. Ensure the gully outlet socket is clean and any hard points should be removed.
2. Place pipe in adaptor and push home.

### Lubricant requirements:

1. Smooth plastic pipe - requires no lubricant.
2. Supersleve pipe - can be jointed dry with care, but lubricant may be used to assist jointing.
3. Densleeve/Hepseal/Corrugated pipes - lubricant such as water/soap, silicone etc. is required for jointing purposes. In some instances for corrugated pipes it may be advisable to place the pipe in the adaptor prior to its location in the gully outlet.

# The Perfect Manhole System

After an extensive research programme, Marshalls CPM introduced the 1200mm perfect manhole system in October 2009 to meet the challenges of modern day construction. Today it is available in 1200mm, 1500mm and 1800mm diameters and comprises of a monolithic precast concrete base (available pre-benched in any configuration within just days of requisition), a sealed chamber ring (with a thicker wall than a traditional ring), a rubber joint (so no tokstrip or similar product is required) and a sealed cover slab (supplied with your required access).

**For other sizes please Telephone: 01538 380500 / Email: [perfect@marshalls.co.uk](mailto:perfect@marshalls.co.uk)**

This unique system of products combine to form the Marshalls CPM perfect manhole system; designed and manufactured to last a minimum of 120 years that provides a sealed manhole system that gives up to 40% savings on greenhouse emissions compared to traditional manhole construction and eliminates the need of ready mixed concrete to form the traditional base, chamber benching and further concrete to surround the manhole.

A complete manhole can be installed in as little as 25 minutes, and making safe site practice a real winner when using the perfect manhole as it reduces the need to work in confined spaces and eliminates the need for wet trades resulting in rapid construction compared to traditional methods as well as a reduction in time for the excavation space to be open.

## The Perfect Installation / Time Line



# Attributes of the Perfect Manhole System

---

- |                 |   |
|-----------------|---|
| ✓ Build Greener | Up to 40% lower greenhouse gas emissions  |
| ✓ Build Leaner  | Saves material and labour / No waste  |
| ✓ Build Faster  | Speedy installation   |
| ✓ Build Safer   | No confined space working, excavation closed quicker                                  |
| ✓ Build Quality | Marshalls CPM Perfect Manhole is produced in a quality controlled factory environment |

## Quality of the Perfect Manhole System

- ✓ Perfect Manhole complies with BSEN1917 and BS5911-3.
- ✓ Marshalls CPM Perfect Manhole is accepted for use by all major UK companies and is included in Sewers for Adoption.

## The long term benefits

- ✓ Marshalls CPM Perfect Manhole is made from high quality durable concrete with a minimum of 120 year design life.
- ✓ Easy access for inspection - reduces maintenance and running costs.
- ✓ Watertight Manhole – prevents water infiltration into the manhole system and ex-filtration of raw sewage or dirty water from the manhole into the surrounding area.

## The Perfect Manhole Take Off Tool / Configurator

Available from Marshalls CPM's website [www.cpm-group.com](http://www.cpm-group.com) is the Perfect Manhole Take Off Tool and Configurator. Just input your 1200mm, 1500mm or 1800mm manhole details and email to [perfect@marshalls.co.uk](mailto:perfect@marshalls.co.uk) and we will send you back a complete schedule and costs for your project.

# Advantages / Perfect Manhole System



## Safer construction

No requirement to form a concrete surround. Reduction of open excavation.



## GHG savings

Up to 40% savings on GHG emissions compared with traditional construction.



## Fast installation

The modular solution eliminates the need for wet trades resulting in rapid construction compared to conventional methods.



## No need to surround in concrete unless specifically required

130mm wall thickness.



## Available at short notice

Our modern methods of production enables just in time delivery of all components including bases at short notice.



## Watertight

The combination of a thicker wall and rubber joints ensures a watertight structure.\*



## No water ingress into sewerage network reduces treatment costs

The combination of a 130mm wall and sealed rubber joint withstand 5m head of pressure.\*



## Combined seal includes load distributor

Load distribution ensures even distribution of vertical loads.



## Allows joint inspection

Correct installation can be visually confirmed.



## Fully tested under factory conditions

The whole system from base to cover slab is subject to testing.



## Kitemarked solution manufactured under factory conditions

Complies with the requirements of BSEN 1917 and BS5911-3



## Concrete for life – built to last

High quality durable concrete with a minimum 120 year design life.



## Flexible connections

The Perfect Manhole can be connected to plastic, clay, cast iron or concrete - giving you a larger choice.

\*Watertightness is defined in BS EN 1917 as resisting a 5m head for 15 minutes. This is to simulate a temporary surcharge condition not a permanent head of water.

\*Shafts in high water tables are subject to buoyancy effects. For further information please contact the Marshalls CPM Technical team.

# Ticking all the boxes



## Efficient construction

Available in varying depths for efficient construction.



## Base options

Available pre-benched or plain bottom with or without inlet / outlets.



## Pre-fit options

Hydro-Brake®, penstocks, non-return valves, and filters can be pre-fitted in the factory.



## Customer choice

The perfect manhole is available with or without double steps. Sealed chamber rings can be used without the perfect base.



## Cover choice

Each perfect manhole is available with a cover slab opening of 600 x 600mm, 675 x 675mm, 750 x 600mm or 1200 x 675mm.

## Extra Services



Full take-off service available



Lifting apparatus available for fast, effective and safe handling



Full installation guide available



Hydro-Brake® / Penstocks and valves can be pre-fitted

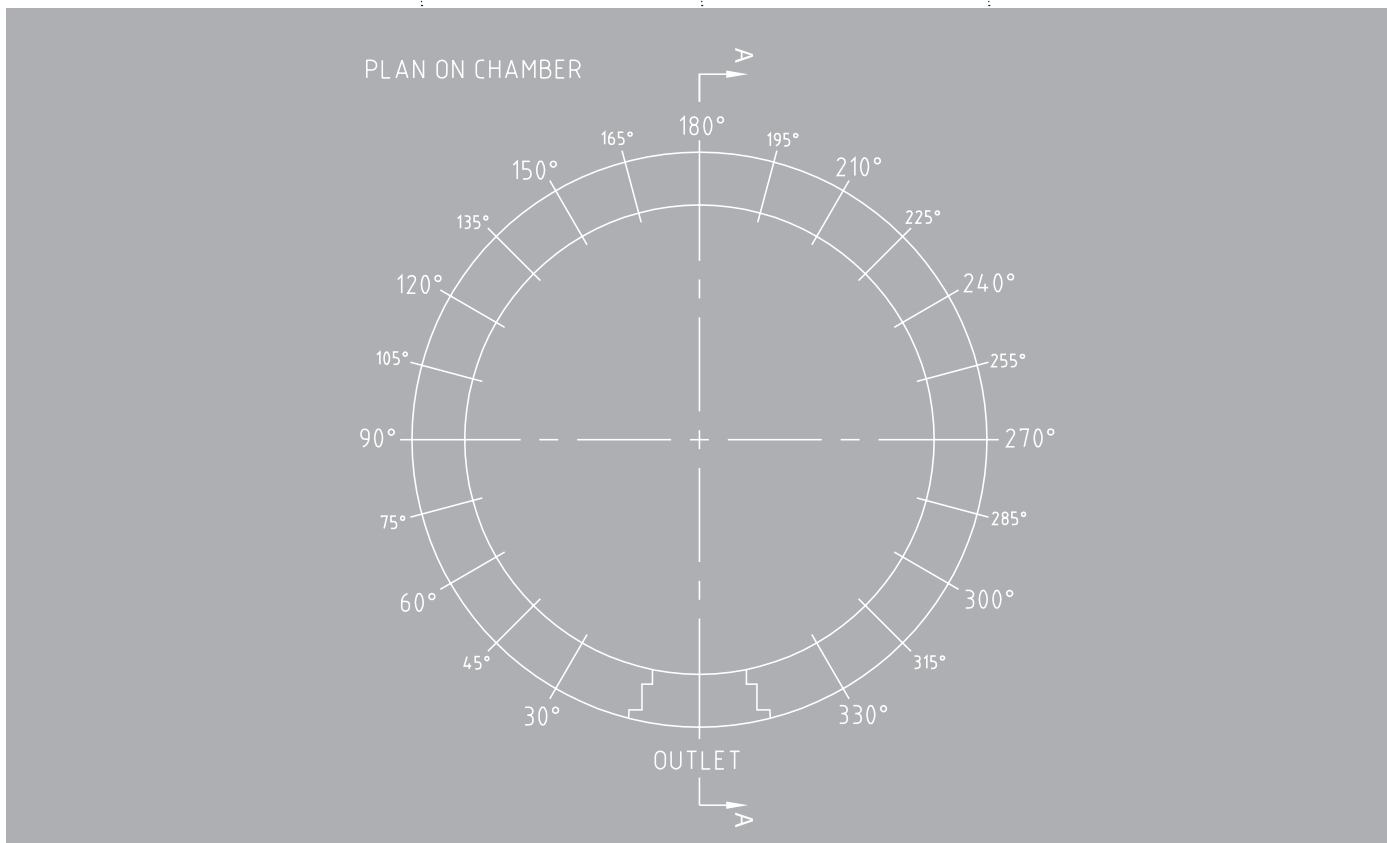
Available in 1200mm, 1500mm and 1800mm diameter

For other sizes please call 01538 380500 or Email: [perfect@marshalls.co.uk](mailto:perfect@marshalls.co.uk)



# Perfect Manhole / Diagrams

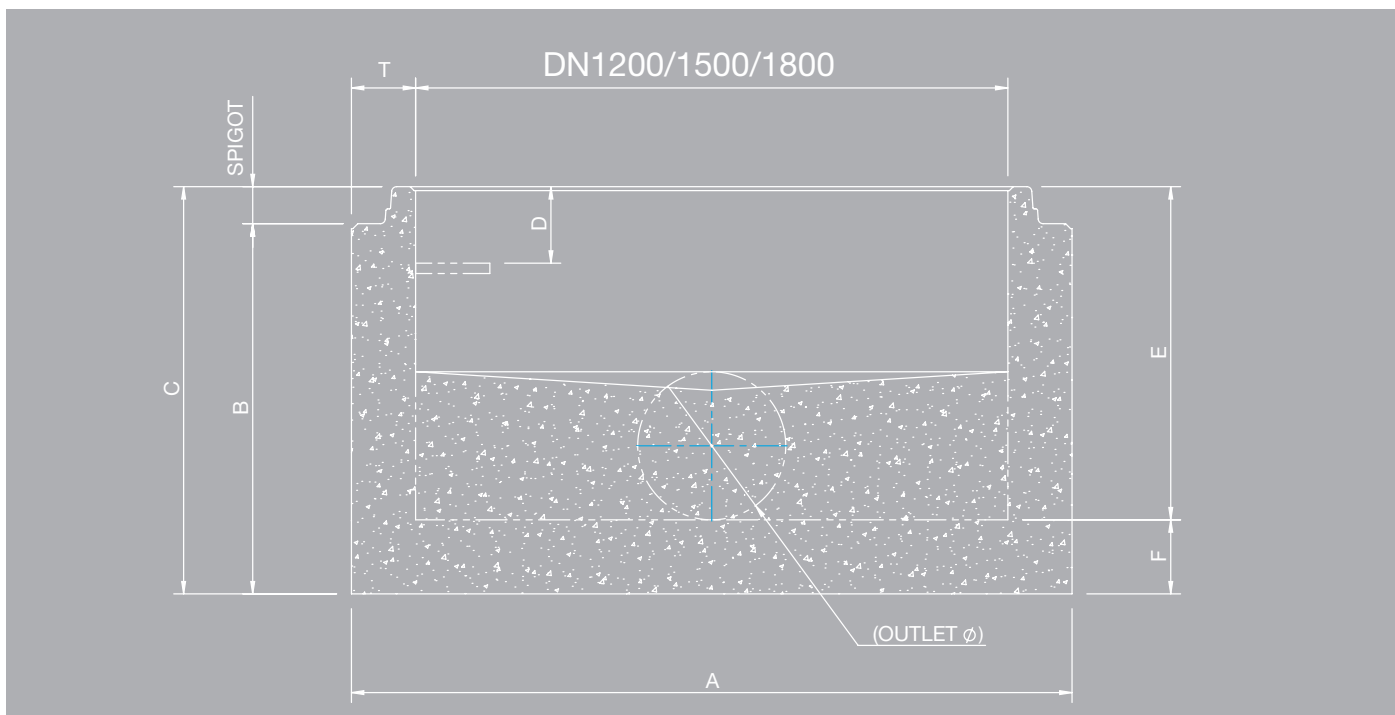
<b>Customer</b>		<b>Product Reference</b>	
<b>Site</b>		<b>Originator</b>	
<b>Customers MH Ref</b>			
<b>Required fall across main channel (E1 To A0)</b>			
<b>Double steps position if Required (DEG)</b>			
<b>Outlet / Inlet Positions (DEG)</b>	<b>Pipe Size</b>	<b>Gradient</b>	<b>Pipe Type</b>
Outlet - A0			
Inlet - E1			
Inlet - E2			
Inlet - E3			
Inlet - E4			



Please use this diagram to scan/photocopy and forward your requirements to [perfect@cpm-group.com](mailto:perfect@cpm-group.com)

Please note that there is a 1 in 9 gradient for the 1200mm perfect manhole and a 1 in 18 gradient for pipes 450mm upwards for the 1500mm perfect manhole and the angles between adjacent connection cannot be less than 24 degrees.

# Perfect Manhole Dimensions / 1200mm



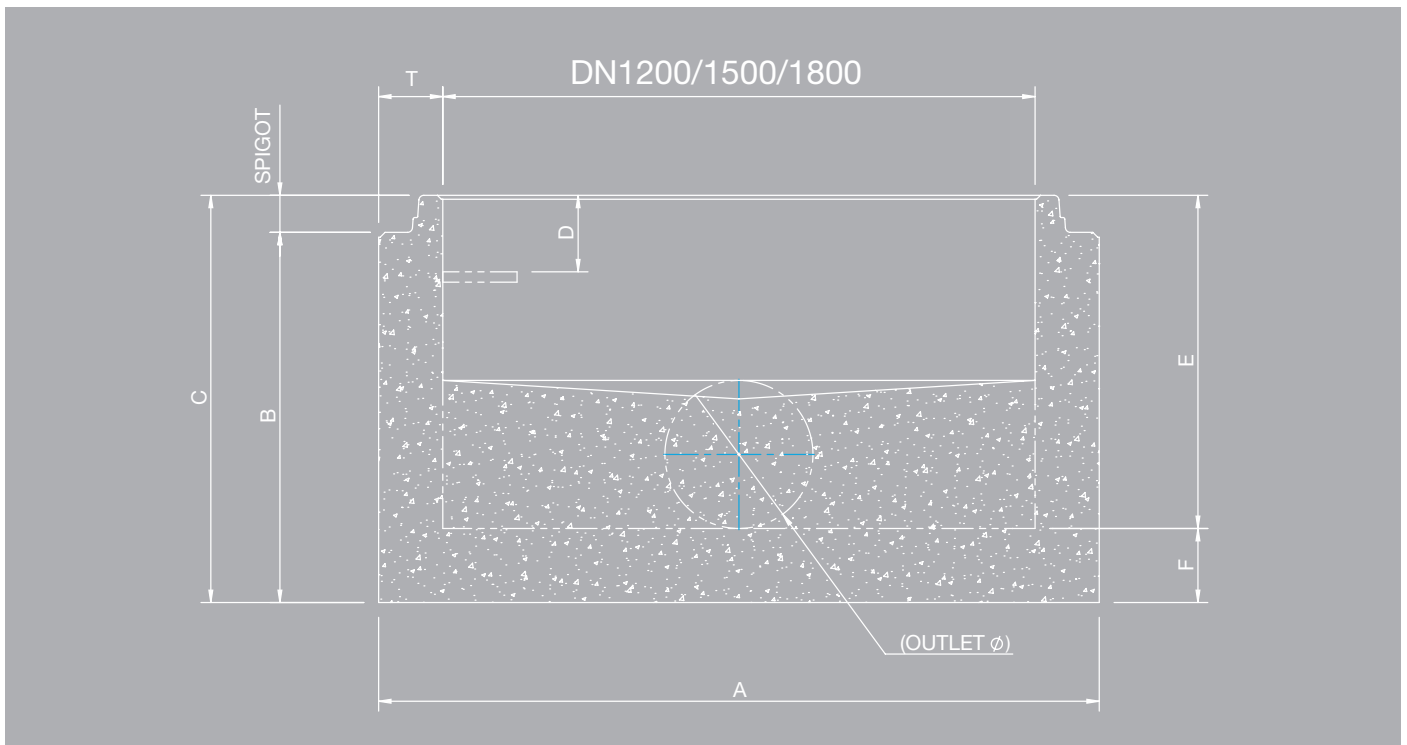
## 1200mm Standard Base Unit

DN1200	Overall Diameter	Product Height		Including Spigot		Depth to Double Step	Depth To Invert		Fill Height	Wall Thickness	Weight (kg)
Dimensions mm	A	B min	B max	C min	C max	D	E min	E max	F	T	Max
100 Diameter Outlet	1460	400	600	475	675	155	325	525	150	130	1550
150 Diameter Outlet	1460	450	650	525	725	155	375	575	150	130	1700
225 Diameter Outlet	1460	525	725	600	800	155	450	650	150	130	1900
300 Diameter Outlet	1460	600	800	675	875	155	525	725	150	130	2100

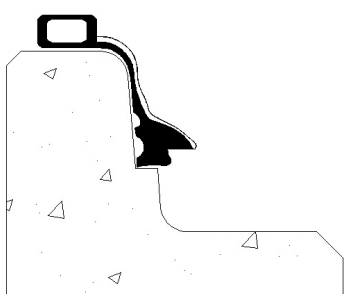
Please note, the maximum and minimum dimensions are spaced over 5 available height variations, which are spaced in 50mm increments. The max weight is based on the tallest unit for that outlet size.

1200mm chambers have a nominal fall of 20mm +/- 10mm north to south across the major incoming to outgoing inlets. Please note that all weights and measures are approximate.

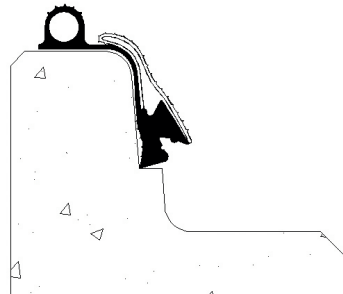
# Perfect Manhole Dimensions / 1500mm



# Perfect Manhole Seals



DS - SDV Seal



Forsheda - F171 Seal

## 1500mm Standard Base Unit

DN1500	Overall Diameter		Product Height		Including Spigot		Depth to Double Step	Depth To Invert		Fill Height	Wall Thickness	Weight (kg)
	A	B min	B max	C min	C max	D	E min	E max	F	T	Max	
100 Diameter Outlet	1820	440	640	525	725	155	375	575	150	160	2450	
150 Diameter Outlet	1820	490	690	575	775	155	425	625	150	160	2750	
225 Diameter Outlet	1820	565	765	650	850	155	500	700	150	160	3100	
300 Diameter Outlet	1820	640	840	725	925	155	575	775	150	160	3450	
375 Diameter Outlet	1820	715	915	800	1000	155	650	850	150	160	3700	
450 Diameter Outlet	1820	815	1015	900	1100	155	725	925	175	160	4050	

Please note, the maximum and minimum dimensions are spaced over 5 available height variations, which are spaced in 50mm increments. The max weight is based on the tallest unit for that outlet size.

1500mm chambers have a nominal fall of 25mm +10mm/-13mm north to south across the major incoming to outgoing inlets. Please note that all weights and measurements are approximate.

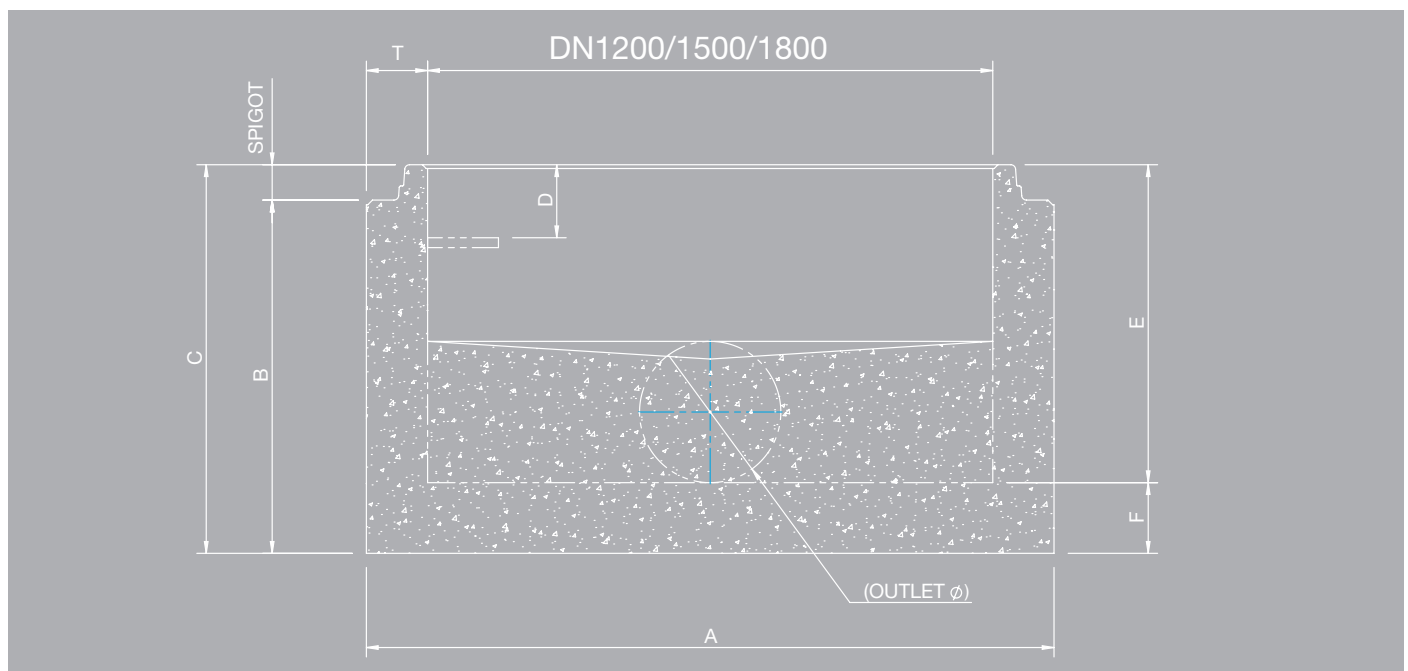
## 1500mm Thick Wall Base Unit

DN1500 Thickwall	Overall Diameter		Product Height		Including Spigot		Depth to Double Step	Depth To Invert		Fill Height	Wall Thickness	Weight (kg)
	A	B min	B max	C min	C max	D	E min	E max	F	T	Max	
525 Diameter Outlet	1960	965	1165	1050	1250	155	850	1050	200	230	5550	
600 Diameter Outlet	1960	1040	1240	1125	1325	155	925	1125	200	230	5850	
675 Diameter Outlet	1960	1115	1315	1200	1400	155	1000	1200	200	230	5950	

Please note, the maximum and minimum dimensions are spaced over 5 available height variations, which are spaced in 50mm increments. The max weight is based on the tallest unit for that outlet size.

1500mm chambers have a nominal fall of 25mm +10mm/-13mm north to south across the major incoming to outgoing inlets. Please note that all weights and measurements are approximate.

# Perfect Manhole Dimensions / 1800mm



DN1800	Overall Diameter	Product Height		Including Spigot		Depth to Double Step	Depth To Invert		Fill Height	Wall Thickness
Dimensions mm	A	B min	B max	C min	C max	D	E min	E max	F	T
100 Diameter Outlet	2440	675	875	760	960	155	485	685	275	320
150 Diameter Outlet	2440	725	925	810	1010	155	535	735	275	320
225 Diameter Outlet	2440	800	1000	885	1085	155	610	810	275	320
300 Diameter Outlet	2440	875	1075	960	1160	155	685	885	275	320
375 Diameter Outlet	2440	950	1150	1035	1235	155	760	960	275	320
400 Diameter Outlet	2440	975	1175	1060	1260	155	785	985	275	320
450 Diameter Outlet	2440	1025	1225	1110	1310	155	835	1035	275	320
525 Diameter Outlet	2440	1100	1300	1185	1385	155	910	1110	275	320
600 Diameter Outlet	2440	1175	1375	1260	1460	155	985	1185	275	320
675 Diameter Outlet	2440	1250	1450	1335	1535	155	1060	1260	275	320
750 Diameter Outlet	2440	1325	1525	1410	1610	155	1135	1335	275	320
825 Diameter Outlet	2440	1400	1600	1485	1685	155	1210	1410	275	320
900 Diameter Outlet	2440	1475	1675	1560	1760	155	1285	1485	275	320

Please note, the maximum and minimum dimensions are spaced over 5 available height variations, which are spaced in 50mm increments.



# Perfect Manhole / Rings

Perfect Manhole Ring Typical Weights	
1200 Dimension mm	Weight kg
1200 x 1500	1950
1200 x 1250	1625
1200 x 1000	1300
1200 x 750	975
1200 x 500	650
1200 x 250	330
1500 Dimension mm	Weight kg
1500 x 1000	1730
1500 x 750	1330
1500 x 500	860
1800 Dimension mm	Weight kg
1800 x 1000	2060
1800 x 750	1545
1800 x 500	1030

# Perfect Manhole / Cover Slabs

Perfect Manhole Cover Slab Typical Weights (kg)				
Dimension	600 X 600 Access	675 X 675 Access	750 X 600 Access	1200 X 675 Access
1200	615	600	600	470
1500	1170	1120	1120	960
1800	1630	1590	1590	1440

Please note that all weights and measures are approximate.

# Box Culverts

Marshall's CPM precast concrete box culverts are designed and manufactured in accordance with EN14 844 and are made in both standard sizes available from stock and a bespoke range that is manufactured to customer specification, ensuring that those who require standard sizes as well as those who require something extra are catered for.

As well as culverts, Marshall's CPM are able to include end walls, access points, vent holes, inlets, outlets, double steps and splayed ends. Starter bars and sockets can be added to facilitate any additional casting on site which may be required as part of the finished work.

The culverts can be supplied as standard units, on their side, vertical chambers and where being used as channels, cover slabs can be supplied separately if required

## Marshall's CPM box culverts suit a wide variety of applications such as:-

- Highways
- Storm and foul sewers
- Sea outfalls
- Tunnels and subways
- Underpasses
- Stream crossings
- Vertical chambers
- Open channels
- Road crossings
- Shafts
- Service tunnels and ducts
- Attenuation and storage tanks
- Water course diversion
- Conveyor protection

An installation guide is available from [www.cpm-group.com](http://www.cpm-group.com) or call 01179 814500 for a copy or email [salesemail@marshalls.co.uk](mailto:salesemail@marshalls.co.uk)

## Typical Box Culverts



## Box Culvert Range

Reference	Eff. Area	Internal Dimensions			External Dimensions		Normal Thickness		Approx Weight
* Stock Item	m.sq	Width m	Height m	Length m	Width m	Height m	Walls mm	Slabs mm	Tonnes
*MC 10.05	0.485	1.000	0.500	2.000	1.30	0.800	150	150	2.77
MC 10.07	0.735	1.000	0.750	2.000	1.300	1.050	150	150	3.14
MC 12.05	0.591	1.250	0.500	2.000	1.550	0.800	150	150	3.24
*MC 12.07	0.904	1.250	0.750	2.000	1.550	1.050	150	150	3.61
MC 13.06	0.826	1.375	0.625	2.000	1.675	0.925	150	1.50	3.61
MC 13.10	1.341	1.375	1.000	2.000	1.675	1.300	150	150	4.17
MC 15.07	1.065	1.500	0.750	2.000	1.80	1.050	150	150	4.12
*MC 15.10	1.440	1.500	1.000	2.000	1.80	1.300	150	150	4.49
MC 15.12	1.815	1.500	1.250	2.000	1.80	1.550	150	150	4.86
MC 15.15	2.190	1.500	1.500	2.000	1.80	1.800	150	150	5.24
*MC 17.07	1.252	1.750	0.750	2.000	2.050	1.050	150	150	4.49
MC 17.10	1.690	1.750	1.000	2.000	2.05	1.300	150	150	4.86
MC 17.15	2.565	1.750	1.500	2.000	2.05	1.800	150	150	5.63
*MC 20.10	1.940	2.000	1.000	2.000	2.30	1.350	150	175	5.79
MC 20.15	2.940	2.000	1.500	2.000	2.30	1.850	150	175	6.54
MC 20.20	3.940	2.000	2.000	2.000	2.30	2.350	150	175	7.20
MC 22.15	3.315	2.250	1.500	2.000	2.55	1.850	150	175	6.98
*MC 25.15	3.690	2.500	1.500	1.500	2.900	1.950	200	225	7.33
MC 24.07 A	1.740	2.400	0.750	1.500	2.800	1.200	200	225	6.050
MC 24.10 A	2.340	2.400	1.000	1.500	2.800	1.450	200	225	6.430
MC 24.12 A	2.820	2.400	1.200	1.500	2.800	1.650	200	225	6.730
MC 24.15 A	3.540	2.400	1.500	1.500	2.800	1.950	200	225	7.170
MC 24.18 A	4.260	2.400	1.800	1.500	2.800	2.250	200	225	7.620
MC 24.21 A	4.980	2.400	2.100	1.500	2.800	2.550	200	225	8.070
MC 27.07 A	1.965	2.700	0.750	1.500	3.150	1.250	225	250	7.370
MC 27.10 A	2.640	2.700	1.000	1.500	3.150	1.500	225	250	7.790

Reference	Eff. Area	Internal Dimensions			External Dimensions		Normal Thickness		Approx Weight
* Stock Item	m.sq	Width m	Height m	Length m	Width m	Height m	Walls mm	Slabs mm	Tonnes
MC 27.12 A	3.180	2.700	1.200	1.500	3.150	1.700	225	250	8.130
MC 27.15 A	3.990	2.700	1.500	1.500	3.150	2.000	225	250	8.630
MC 27.18 A	4.800	2.700	1.800	1.500	3.150	2.300	225	250	9.140
MC 27.21 A	5.610	2.700	2.100	1.500	3.150	2.600	225	250	9.640
MC 30.07 A	2.190	3.000	0.750	1.500	3.150	1.250	225	250	7.930
MC 30.10 A	2.940	3.000	1.000	1.500	3.450	1.500	225	250	8.350
MC 30.12 A	3.540	3.000	1.200	1.500	3.450	1.700	225	250	8.690
MC 30.15 A	4.440	3.000	1.500	1.500	3.450	2.000	225	250	9.190
MC 30.18 A	5.340	3.000	1.800	1.500	3.450	2.300	225	250	9.700
MC 30.21 A	6.240	3.000	2.100	1.500	3.450	2.600	225	250	10.200
MC 33.07 A	2.415	3.300	0.750	1.500	3.750	1.250	225	250	8.490
MC 33.10 A	3.240	3.300	1.000	1.500	3.750	1.500	225	250	8.910
MC 33.12 A	3.900	3.300	1.200	1.500	3.750	1.700	225	250	9.250
MC 33.15 A	4.890	3.300	1.500	1.500	3.750	2.000	225	250	9.750
MC 33.18 A	5.880	3.300	1.800	1.500	3.750	2.300	225	250	10.260
MC 33.21 A	6.870	3.300	2.100	1.500	3.750	2.600	225	250	10.760
MC 36.07 A	2.640	3.600	0.750	1.500	4.050	1.250	225	250	9.050
MC 36.10 A	3.540	3.600	1.000	1.500	4.050	1.500	225	250	9.470
MC 36.12 A	4.260	3.600	1.200	1.500	4.050	1.700	225	250	9.810
MC 36.15 A	5.340	3.600	1.500	1.500	4.050	2.000	225	250	10.310
MC 36.18 A	6.420	3.600	1.800	1.500	4.050	2.300	225	250	10.820
MC 36.21 A	7.500	3.600	2.100	1.500	4.050	2.600	225	250	11.320
MC 39.07 A	2.865	3.900	0.750	1.500	4.350	1.250	225	250	9.612
MC 39.10 A	3.840	3.900	1.000	1.500	4.350	1.500	225	250	10.033
MC 39.12 A	4.620	3.900	1.200	1.500	4.350	1.700	225	250	10.369
MC 39.15 A	5.790	3.900	1.500	1.500	4.350	2.000	225	250	10.873
MC 39.18 A	6.960	3.900	1.800	1.500	4.350	2.300	225	250	11.378
MC 39.21 A	8.130	3.900	2.100	1.500	4.350	2.600	225	250	11.882
MC 42.07 A	3.090	4.200	0.750	1.500	4.650	1.250	225	250	10.173

Reference	Eff. Area	Internal Dimensions			External Dimensions		Normal Thickness		Approx Weight
* Stock Item	m.sq	Width m	Height m	Length m	Width m	Height m	Walls mm	Slabs mm	Tonnes
MC 42.10 A	4.140	4.200	1.000	1.500	4.650	1.500	225	250	10.593
MC 42.12 A	4.980	4.200	1.200	1.500	4.650	1.700	225	250	10.929
MC 42.15 A	6.240	4.200	1.500	1.500	4.650	2.000	225	250	11.434
MC 42.18 A	7.500	4.200	1.800	1.500	4.650	2.300	225	250	11.938
MC 42.21 A	8.760	4.200	2.100	1.500	4.650	2.600	225	250	12.443

**Table Notes:**

A Adjustable size mould range -

Details of splays:

- MC 10.05 to MC 10.07 : 150 x 50mm
- MC 12.05 to MC 13.10 incl : 225 x 75mm
- MC 15.07 upwards : 300 x 100mm



## Typical Box Culvert Images





# Headwalls

Marshalls CPM have developed a precast concrete headwall system that is designed to connect pipe work discharge into open water course. This offers a cost effective alternative to in-situ structures.

The Marshalls CPM headwalls control erosion and scour resulting from excessive velocities and turbulences and prevent adjacent soil from sloughing into the watercourse opening.

## Benefits of Marshalls CPM Headwall include:

- Able to accommodate pipe-work up to and including 900
- Can be pre-fitted with closed coupled and cranked gratings
- Four standard sizes available as well as a range of bespoke options
- Can be pre-fitted with various accessories including: Hydro-Brakes, Penstocks and Non-return Flap Valves
- Prefabricated off site under factory conditions, minimising on site skilled labour
- Most cost effective than an in-situ unit with no on site shuttering or formwork required
- Greatly reduced installation time, minimising on site labour and site costs
- Low maintenance required
- A real cost effective solution that's quick and easy to install

Marshalls CPM precast headwalls control erosion and scour resulting from excessive velocities and turbulences and prevent adjacent soil from sloughing into the watercourse opening.



## Headwall Sizes / Dimensions / Drawings

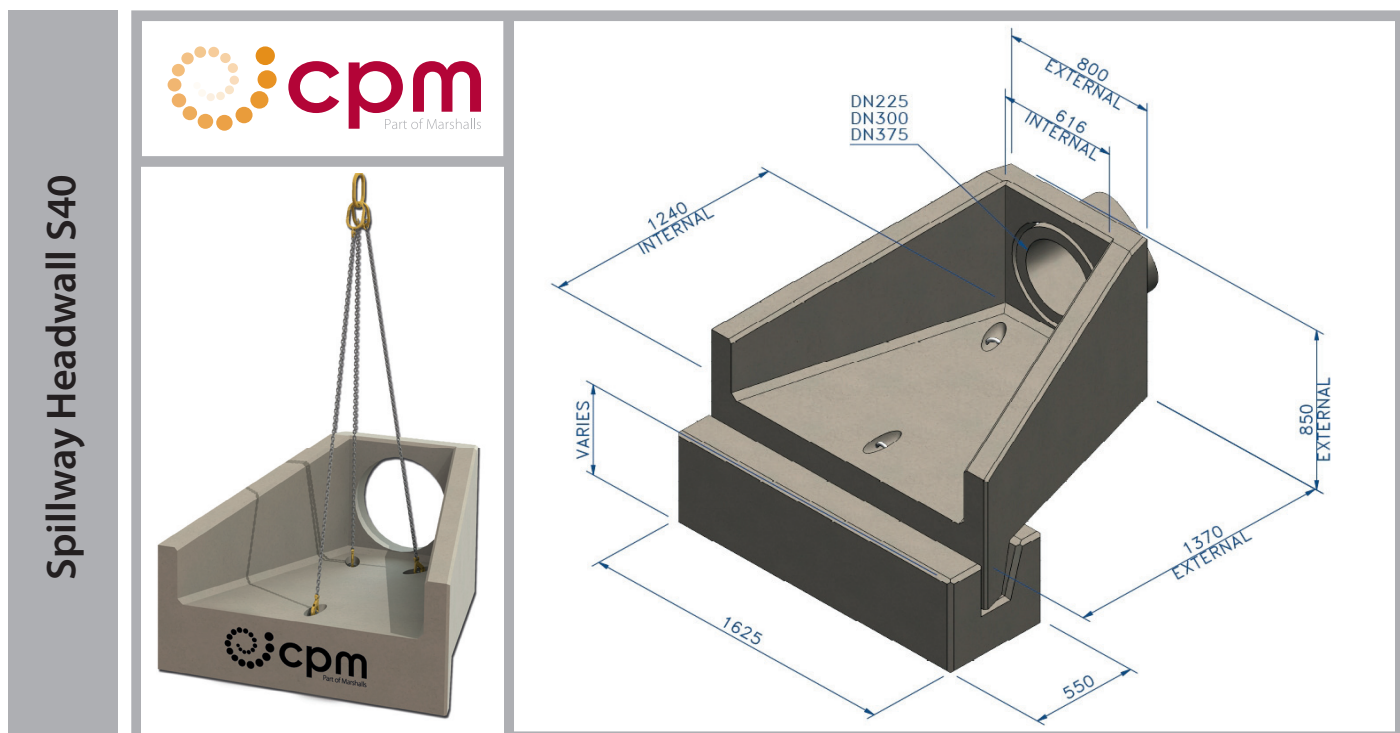
Headwall Sizes	Pipe Diameters
S20	Up to 300
S40	Up to 375
S60	Up to 600
S90	Up to 900

S40 XH and S60 XH available with additional back wall

### Hole Sizes

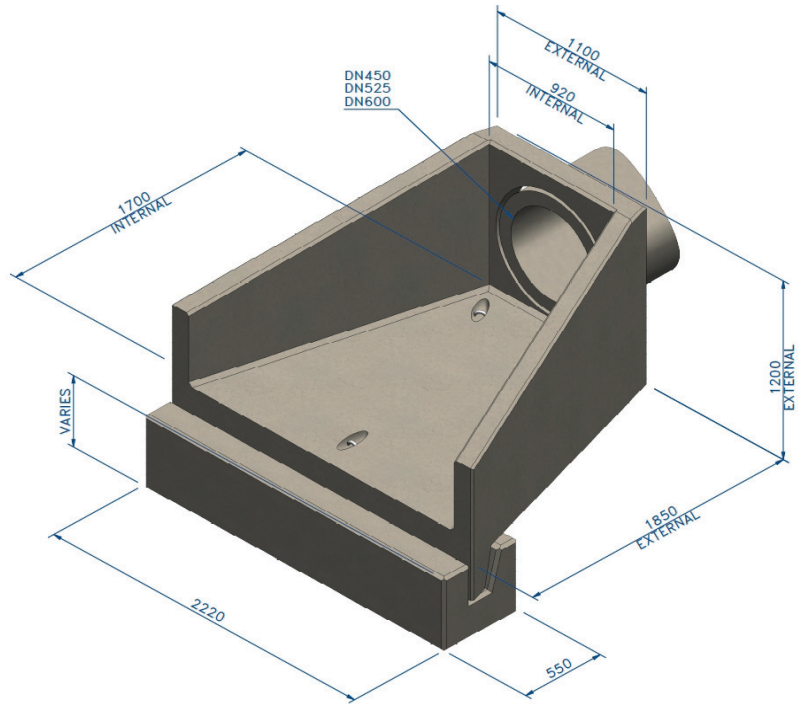
Designed Pipe Diameter	Minimum Hole Size	S20	S40*	S60*	S90
100	130	•			
150	198	•	•	•	•
225	320	•	•	•	•
300	460	•	•	•	•
375	540		•	•	•
450	635			✓	•
525	720			✓	•
600	825			✓	•
675	870				✓
750	950				✓
825	1035				✓
900	1135				✓

Table Key: • = stock item ✓ = made to order \* = steeper embankment version available



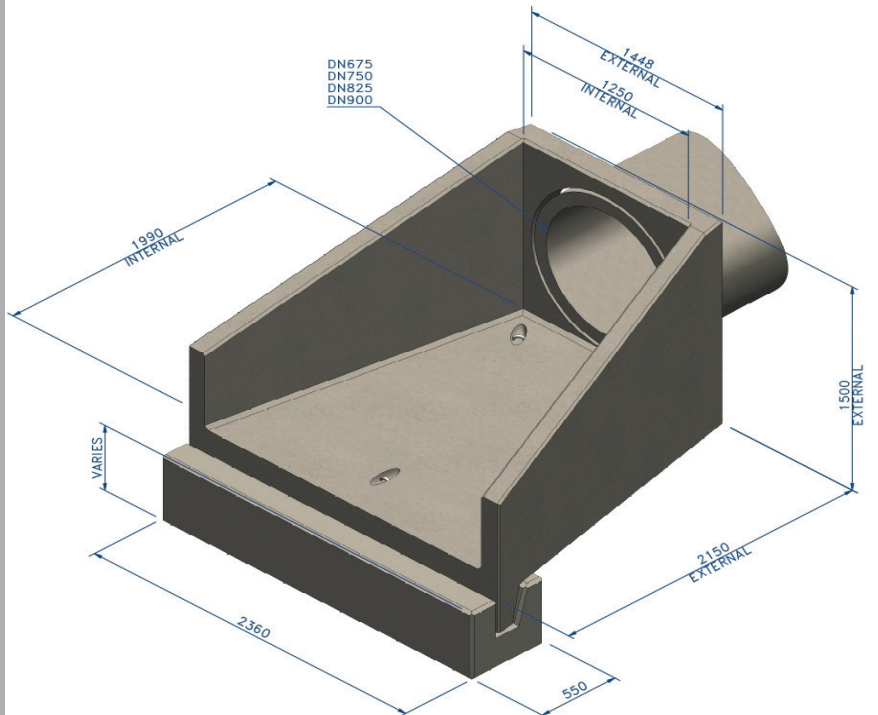
Available with extra height back wall if required (S40XH)

Spillway Headwall S60



Available with extra height back wall if required (S60XH)

Spillway Headwall S90



# Catchpit / Silt trap chamber systems

Marshalls CPM has developed a range of one-piece catchpit and silt trap manholes, so why spend days constructing an in-situ catch-pit manhole on site, when one-piece chambers are available and can be installed within hours, not days!

The reinforced watertight one-piece structures offer greater design flexibility with a range of cored or pre-formed holes/cut-outs for inlet/outlet holes which come complete with seals. Marshalls CPM modular catchpits save money and time as they are built under factory conditions to your specification ensuring dimensional correctness as well as a high quality finish. The catchpit is designed in line with highway specifications.

## Design options include:

- 1050mm to 3000mm standard tongue and groove complete with a cast-in reinforced base
- 1200mm, 1500mm and 1800mm sealed manhole joint complete with cast-in reinforced base
- Pipe inlet/outlet diameters of up to DN1800 covered.

## Benefits of using a Marshalls CPM catchpit and silt trap

- Reduced costs in construction time and on-site personnel
- Sump depths to suit design requirements
- Accommodates uPVC, twinwall, clay, ductile iron and concrete
- Increased Health and Safety benefits as it reduces on-site construction
- Reduces wet trades for manhole construction
- Product is made and tested under factory conditions
- Eliminates extra transport and material wastage used with on-site construction methods
- Chamber bases are Kitemarked
- 1050mm unit weighs less than one tonne
- Bespoke design to suit customer requirements
- Standard tongue and groove joints
- Greatly reduced installation time on site
- None or minimal on-site fabrication required
- Designed in line with highway specifications





# Preformed Manholes

Marshall's CPM has developed an off-site large modular manhole system that is designed to speed up the installation whilst providing a safe working environment for personnel working within the manhole.

## The benefits of the wide wall section include:

- An established and proven product range that is Quality Assured
- Wide wall products are supplied with a Butyl sealant which removes the need for a concrete surround
- The chamber is supplied with a reinforced cast-in base
- The chamber system provides preformed inlet and outlet holes to suit pipe requirements
- The chambers are manufactured in fixed steel moulds that give a superior dimensional accuracy
- Wide wall chambers have an inherent structural concrete strength with a 120 year design life
- Chamber units are supplied with cast-in lifting points.
- AutoCAD drawings can be provided
- Kitemarked product range

## Product specifications include:

- All chamber sections are manufactured to the requirements of BS5911-3, (2100mm, 2400mm, 2700mm and 3000mm are kitemarked).
- The base chamber is manufactured with a minimum 200mm deep; grade C40, reinforced concrete base dowed into the chamber unit.
- The inlets and outlets are either pre-scored, pre-formed or cored holes (depending on size) to suit the customer's requirements.
- Cover slabs are manufactured to the requirements of BS EN 1917 and BS 5911-3, unless otherwise specified.

Nominal Diameter (mm)	Outside Diameter (mm)	Weight per 500mm (kg)	Weight per 750mm (kg)	Weight per 1000mm (kg)
2100	2350	1070	1605	2140
2400	2680	1370	2055	2740
2700	3000	1700	2550	3400
3000	3330	2070	3105	4140
3660	4030	N/A	3980	5300
4000	4400	N/A	4770	6360



For an installation sequence please see our website: [www.cpm-group.com](http://www.cpm-group.com)



# Direct Access Pipe Systems

Marshalls CPM has developed and manufactured an off-site manhole for large diameter concrete pipe systems that completely removes the need for a traditional manholes, any on-site benching or concrete surround. The system incorporates the highly successful, and Sewers for Adoption approved, sealed manhole joint system.

With all components suitable for use in wide ranging situations including on-line storage, single or multiple off-line tank systems, the Direct Access Pipe System has proven successful in replacing large diameter traditional manholes.

## Advantages of the Direct Access Pipe System

- Modern method of manufacture giving a quality, dimensional accurate product
- Reduced footprint, with 1200mm sealed manhole shaft access
- Reduction in the time taken to build manholes, from many days to just hours
- Greatly reduced Health and Safety risks
- Removes the need for any benching on site or concrete back-fill
- Economic method for access to tank systems eliminating the requirement for a traditional manhole, with for man or non-man access
- Long term easy access into the system for maintenance
- Watertight joints to both pipes and manholes, including load bearing seals
- Established and proven product range that is Quality Assured
- Inherent structural strength of concrete with an 120 year design life
- System can be designed to suit most structural and hydraulic specifications including installation under roads
- Flow control devices can be incorporated into the system, such as Hydro-Brakes®, Orifice Plates, Penstocks or a combination of all
- AutoCAD drawings can be provided



## End Entry Manholes

An end entry manhole is used at the end of either an in-line or off-line tank, consisting of a standard pipe with a reinforced end wall, saddle slab pre-fitted onto the barrel complete with an access hole to suit and a 1200mm sealed manhole joint.

A 1200mm sealed manhole shaft can be used to make up the desired height with inlet and outlet connections cored or formed to suit your drainage requirements. An internal side wall can be incorporated in the end of the pipe if required, as well as double steps or ladders to permit access.

An end entry manhole is classified as a junction within the scope of BS EN 1916:2002

Available from 1200mm and above, smaller diameters can be manufactured upon request, please call 01179 814500 for details.



1800mm end entry and 1800 off 1800mm wet well for an integrated wet well and storage tank



1200mm end entry manhole complete with hydrobrake



1800mm end entry manhole

## Side Entry Manholes

Side entry manholes are normally used to gain mid run access entry into in-line or off-line tanks and consists of a standard concrete pipe complete with access shaft.

Depending upon the overall depth, a sealed manhole cover slab or reducing slab to a 1200mm sealed manhole complete with a load bearing seal can be supplied. 1200mm rings are used to make up the desired shaft height and double steps or ladders can be fitted into the unit.

Side entry manholes can be supplied with a separate bend to provide a change of direction and access can be to either side of the pipe.

Side entry manholes are classified as a junction within the scope of BS EN 1916:2002

The side entry manhole is available from 1200mm and above, however if you require a smaller size please call: 01179 814500

## Mid Entry Manholes

Mid entry manholes are usually used for mid run access into either in-line or off-line tanks and consist of a standard pipe with a saddle slab and cored access hole. The saddle slab has a joint for a 1200mm sealed manhole to fit onto and can be further reduced to restrict access for cameras only.

Available from 1350mm and above, the system is designed for access only with a winch or via a removable ladder into the main tank and can be supplied with a separate bend to provide a change of direction should you wish. If you require a smaller diameter please call: 01179 814500.

Mid entry manholes are classified as a junction/bend within the scope of BS EN 1916



900mm off 900mm mid entry manhole



1600mm side entry manhole



End entry manholes

## Side and Mid Entry Manholes complete with a bend

A side or mid entry manhole complete with bend is an economic method for access to a tank system, eliminating the requirement for a traditional manhole and is usually used for mid access into an in-line run requiring a change of direction, it consists of a side or mid entry manhole that incorporates a bend in the barrel of the pipe.

The side and mid entry manhole is available on 900mm to 1800mm pipe sizes, depending upon the bend angle and manhole type, sealed manhole shafts can be used to make up the desired height with double steps or ladders being fitted to permit access.

A side and mid entry manhole complete with bend is classified as a junction/bend within the scope of BS EN 1916.



1200mm end entry complete with 450mm hole



1200mm side entry being manufactured



1200mm side entry run being installed

### Stop End Bends

Stop end bends consist of a 90° bend used in an upright position as an access into the pipeline and are mainly used at the downstream end depending upon the overall depth required, 1200mm manhole shaft can be used to make-up the desired height, with double steps or ladders being incorporated into the unit to permit access.

Inlet and outlet connections can be cored or formed to suit drainage requirements. Stop end bends are available from 1200mm diameter and above, although smaller diameters can be manufactured upon request.

Stop end bends are classified as a bend within the scope of BS EN 1916:2002

Please call: 01179 814500 or email: [watermanagement@marshalls.co.uk](mailto:watermanagement@marshalls.co.uk)



1200mm stop end bend complete with high level inlet



1350mm stop end bend complete with high level inlet



Stop end bend complete with low level outlet



## Stop End Pipes

A stop end pipe is normally used at the end of an off-line tank and do not include access points.

They can be manufactured with an inlet and outlet hole at any position with any diameter hole size complete with a seal. The 200mm thick reinforced concrete end wall has a dowelled connection complete with a Hydrotite seal, to achieve a waterproof connection.

Stop end manholes are available across the Marshalls CPM standard length pipe range.



## Integrated Pipe Flow Control Chambers

Marshalls CPM integrated pipe flow control chambers have been designed to keep the flow control chamber the same internal diameter as the pipe. This system is commonly used for in-line attenuation schemes in sizes ranging from 1200mm to 1800mm



1500mm off 1500mm complete with side wall, sump and pre-fitted penstock



1600mm off 1600mm complete with pre-fitted Hydro-Brake® on headwall



1600mm off 1600mm flow control chamber



# One-Piece Chamber Systems

Marshall's CPM has developed chamber systems in 1800mm and 2100mm diameter that can be manufactured up to 2500mm deep in a single part. These chambers can be supplied complete with pre-fitted butt pipes or connections to suit large ovoids and circular pipes.



2500mm deep one-piece chamber complete with ovoid butt and channel



Single part 1800mm sealed manhole complete with pre-fitted 1200mm butt



2100mm diameter wide wall manhole complete with pre-fitted ovoid butt and channel plus internal back-drop junction

# Large Sectional Wide Wall Chambers

Marshall's CPM introduced the sectional chamber system as a quicker and safer alternative to traditional methods of manhole construction. Available from 2100mm to 3660mm complete with formed inlet and outlet holes to suit, sectional wide wall flow control chambers are designed for use when either weight or access is an issue on site.



3000mm sectional chamber installation with a letter box opening for 1500mm concrete pipe



2550mm sectional installation, base chamber complete with half formed hole for 750mm pipe



2550mm sectional installation, upper ring with half formed hole for 900mm pipe and formed inlet hole



# Flow Control Chamber Systems

Marshalls CPM has been developing flow control chamber systems for over 10 years and can now provide a comprehensive range of precast solutions to suit most customer requirements.

Chamber systems can be pre-fitted with many different types of flow control devices from Hydro-Brakes® developed in a joint venture with Hydro International, penstocks, non return flap valves or orifice plates or any combination of all types. Chambers can come as complete units depending upon weight or as a sectional system for sites that have access or weight lifting restrictions.

None of the systems supplied by Marshalls CPM require a full concrete surround and have been designed to be installed in a fraction of the time taken using conventional methods.

## Standard Sealed Manhole Flow Control Chambers

Following the success of the sealed manhole system, Marshalls CPM has further developed the 1200mm and 1500mm manholes to include one-piece flow control chambers incorporating a base, headwall and benching. The 1800mm sealed and 2100 wide wall chamber versions are supplied with a headwall and base



1200mm sealed manhole, complete with pre-fitted Hydro-Brake®



1500mm Hydro-Brake® chamber complete with 750mm inlet butt



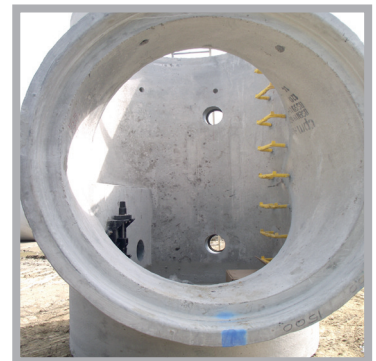
1800mm sealed chamber complete with Optimum Hydro-Brake®



2100mm wide wall chambers complete with Optimum Hydro-Brake®



Hydro International Downstream Defenders® with vortex separator



1500mm integrated flow control for attenuation tank

### Sectional Wide Wall Flow Control Chambers

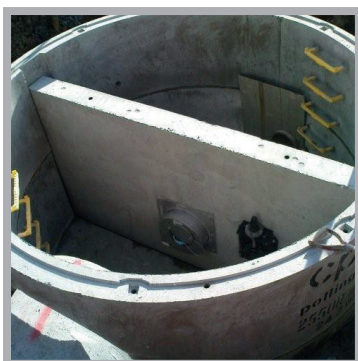
Marshalls CPM have developed a range of sectional wide wall chamber systems for 2100mm to 3000mm, suitable for use with Hydro-Brakes®, penstocks, flap valves or any other flow control devices.



3000mm wide wall chamber complete with a separate bolted headwall and CX Hydro-Brake®

### Weir Wall Chambers

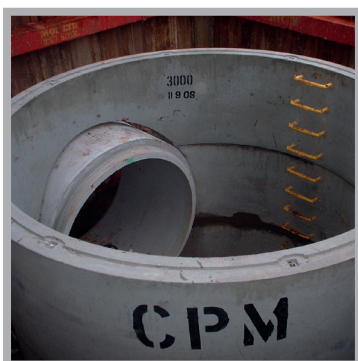
Marshalls CPM can supply either sectional weir wall chambers from 1500mm to 3000mm diameter or a 2100mm one-piece unit. The weir wall can be manufactured to any height and be supplied with pre-fitted flow control devices.



2550mm wide wall chamber installed complete with Hydro-Brake® and penstock on weir wall.



1800mm sealed sectional weir wall chamber base complete with a 750mm pipe cast-in to the base.



3000mm wide wall sectional chamber, 1800mm inlet and 1050mm outlet, pre-fitted Hydro-Brake® and penstock.



Wide wall chamber complete with sectional side wall, pre-fitted Hydro-Brake® and non return flap valve.

## Split Wall Chambers

The split wall chamber has been designed to allow for inspection of either side of the flow control device. Marshalls CPM can supply either sectional weir wall chambers from 1800mm to 3000mm or a 2100mm one-piece unit.

The split wall chamber can be manufactured to any height and be supplied with pre-fitted flow control devices



Sectional wide wall chamber complete with split wall and pre-fitted Hydro-Brake® and penstock



Wide wall chamber complete with split wall and pre-fitted Hydro-Brake®

## Complex Flow Chambers

Marshalls CPM complex flow control chambers can be supplied in any of our chamber systems. The term complex flow is used when different storm events need an individual control, i.e. 1 in 20, 1 in 50 etc, requiring the installation of two or more flow control devices.



Weir wall chamber complete with two pre-fitted Hydro-Brakes®



2000mm sectional weir wall chamber complete with two pre-fitted Hydro-Brakes®



# Bespoke Chamber Systems

## Flat Pack Chambers

Marshall's CPM has developed a flat pack chamber system that can be used in situations where conventional circular chambers are not appropriate. The chamber size can be manufactured to suit most dimensional requirements and the system comes with pre-fitted watertight wall seals at joints.



Flat pack chamber with base



Flat pack side



Double height flat pack system



Bolted flatpack



Bolted flatpack



Flat pack chamber







## Downstream Defender®

Marshalls CPM in a joint venture with Hydro International has introduced a Stormwater treatment system called the Downstream Defender®, an advanced hydrodynamic vortex separator.

The Downstream Defender® is an advanced hydrodynamic vortex separator for the effective and reliable removal of fine particles along with oils and other floatable debris from surface water runoff.

Its innovative design delivers high efficiency across a wide range of flows in a much smaller footprint than conventional or other swirl-type devices and is the perfect choice for any catchment likely to convey high quantities of contamination.

## Targeted Pollutants

Marshalls CPM complex flow control chambers can be supplied in any of our chamber systems.

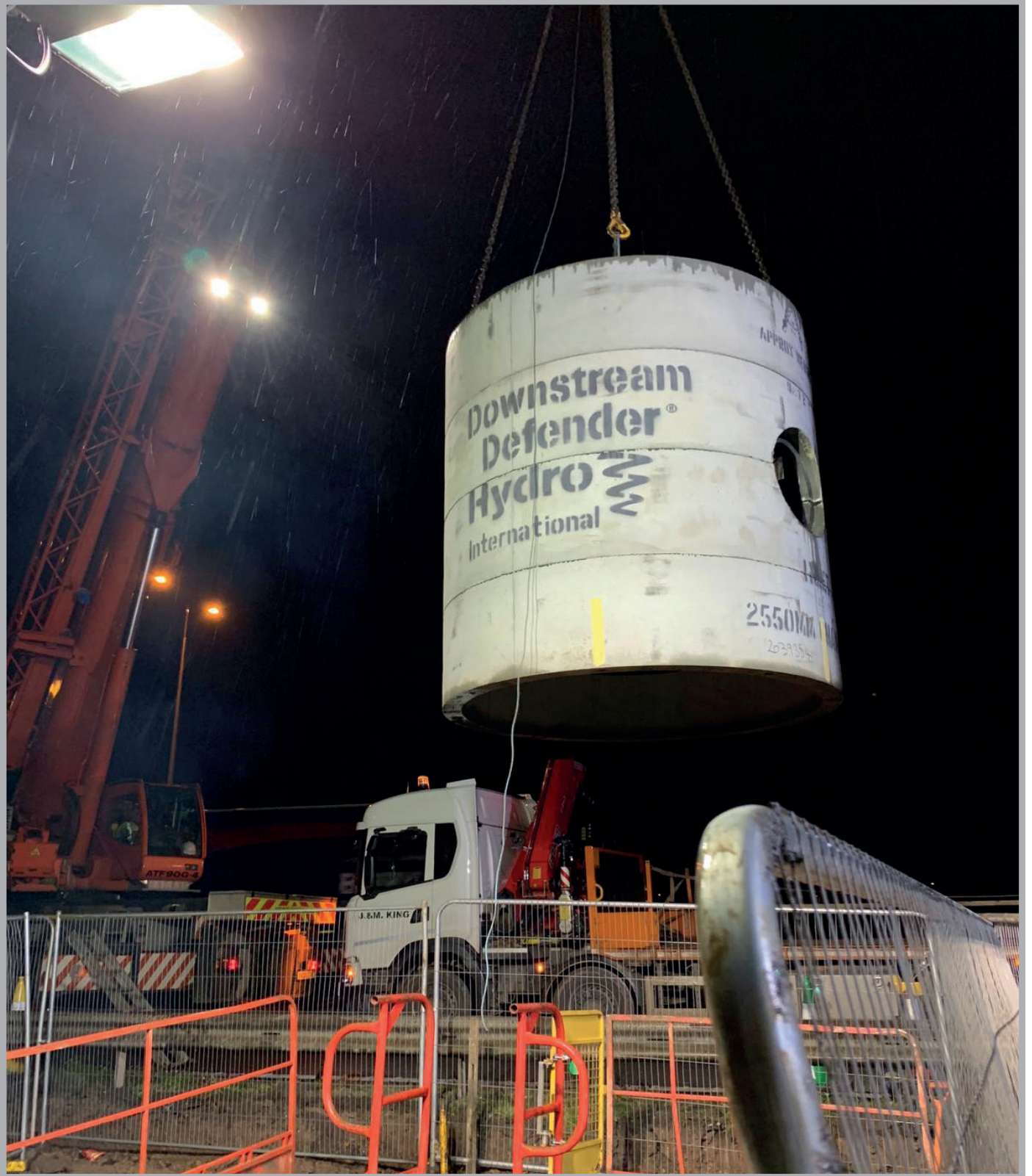
The term complex flow is used when different storm events need an individual control, i.e. 1 in 20, 1 in 50 etc, requiring the installation of two or more flow control devices.

- Fine particles
- Gross pollutants
- Liquid and sediment bound hydrocarbons
- Sediment bound heavy metals
- Sediment bound nutrients

The Downstream Defender® has unique flow modifying components that have been optimised to deliver unsurpassed capture and retention of pollutants during both frequent and extreme rainfall events. It delivers high removal of pollutants through advanced hydrodynamic vortex separation across a wide range of flows, achieving a long, stable flow path to maximise pollutant capture from surface runoff.

The device is able to tackle an assortment of pollutants including gross debris, litter, hydrocarbons, coarse sediments, fine sediments and particulate organics.







## First Defense®

The First Defense® is an economical hydrodynamic vortex separator for effective removal of sediment, litter and oil from surface water runoff. Captured pollutants are kept safely within the device keeping public areas free from harmful pollutants

Suitable for at-source pollution control in small to medium size catchments, the First Defense® provides space-saving, easy-to-install surface water treatment in a standard size precast concrete manhole.

## Targeted Pollutants

Marshalls CPM complex flow control chambers can be supplied in any of our chamber systems.

The term complex flow is used when different storm events need an individual control, i.e. 1 in 20, 1 in 50 etc, requiring the installation of two or more flow control devices.

- Coarse particles
- Liquid and sediment bound hydrocarbons
- Gross pollutants



**Convey Control Store Treat Release**

## Biofilter™

The Marshalls CPM Biofilter™ is an innovation biofiltration system that harnesses the natural treatment action of vegetation and the filtration power of specially engineered soils.

Above ground the Marshalls CPM Biofilter™ looks like a normal tree box, with a suitable plant or small tree growing through the decorative grating in a precast concrete cover slab at pavement level. Underneath, the precast concrete chamber contains a layer of enhanced mulch on top of a unique soil filter medium to deliver high levels of surface water treatment.

Surface water is channelled into the Biofilter™ through a kerbside inlet, through an inlet pipe or directly from the surface and flows through the mulch, plant and soil filter media, providing high-performance, high-flow filtration that targets sediment, hydrocarbons, heavy metals and nutrients.

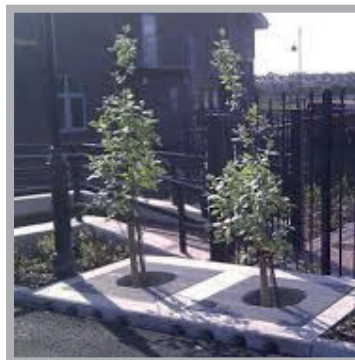
## Targeted Pollutants

Marshalls CPM complex flow control chambers can be supplied in any of our chamber systems.

The term complex flow is used when different storm events need an individual control, i.e. 1 in 20, 1 in 50 etc, requiring the installation of two or more flow control devices.

- Very fine particles
- Dissolved, liquid and sediment bound hydrocarbons
- Gross pollutants
- Sediment bound heavy metals
- Sediment bound nutrients
- Dissolved pollutants

The Marshalls CPM Biofilter engineers in nature's way to enhance any urban environment even where space is at a premium or where a retrofit surface water treatment solution is required. Suitable for residential or commercial settings, car parks and roadways.



## Up-Flo™ Filter

The Up-Flo™ Filter is an innovative surface water filtration technology that delivers a high-performance multi-stage treatment process within a single device. The Up-Flo™ Filter combines sedimentation screening with fluidised bed filtration technology to deliver high levels of performance.

Easy to maintain and with low construction costs, the Up-Flo™ Filter achieves a high quality of surface water discharge in a much smaller footprint than alternative systems.

### Targeted Pollutants

- Very fine particles
- Gross pollutants
- Liquid and sediment bound hydrocarbons
- Sediment bound heavy metals
- Sediment bound nutrients

The unique Hydro Up-Flo™ Filter combines multiple, sequential treatment processes to deliver sedimentation, screening and filtration all in one compact unit. The Up-Flo™ Filter removes litter, sediments, nutrients, metals and hydrocarbons. Specific pollutants can be targeted through a wide choice of media options.

### Reliable Performance

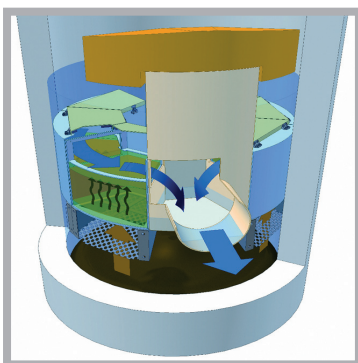
During extreme rainfall events, a high-flow bypass system is activated preventing the drainage network from being overloaded. All storm flows up to and including the bypass flow are retained within the device, so there is no surface ponding. Retaining pollutants within the drainage system also avoids excessive build-up of contamination and toxicity issues that could otherwise accumulate in plants and animals (bioaccumulation).

### Easy Installation for Trouble-Free Construction

The Up-Flo™ Filter is supplied fully assembled in a precast concrete manhole for easy installation. Its advanced filter units can also be simply retrofitted into an existing chamber on-site.

### Simple and Cost-Effective Maintenance

The gentle and effective action of the Up-Flo™ Filter ensures filtration media have a much longer life than comparable systems, so maintenance is infrequent, cost-effective and simple. The filter media packs can be exchanged manually without the need for specialist equipment. Sediment collected in the sump is removed with a standard vacuum tanker





## Pump Chamber

Marshalls CPM produces a range of wet well pump chambers that are available in either a sealed manhole or wide wall chamber system. Chambers can have pre-cored holes to suit or can be pre-fitted with pipe equipment to suit.

Heavy duty cover slabs with rebated accesses and pre-fitted davit sockets can be manufactured to suit most dimensional requirements.



2100mm base chamber and section complete with pump pipework cut out in chamber wall



2100mm chamber with pipework cut out in chamber wall



2100mm base chamber pre-fitted with non return flap valve in chamber wall

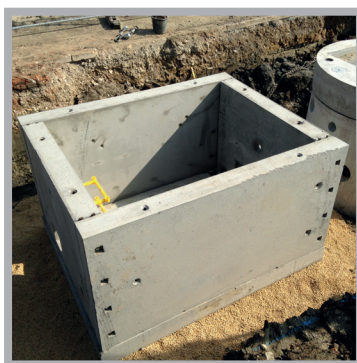
## Flat Pack

Marshalls CPM has developed a range of valve chambers that can be supplied as a complete chamber or as a flat pack chamber.

Chambers can be supplied with pre-cored holes or be pre-fitted with pipe equipment to suit. Cover slabs can be rebated to take an access cover or heavy duty cover slab (with rebated accesses if required) which can be manufactured to suit most dimensional requirements.



Once-piece chamber with inlet and outlet holes



Flat pack installation



Flat pack chamber complete with rebated cover slab for access cover





Convey Control Store Treat Release



# T-T READY SUMP® / Features / Benefits



- Smooth and clean design
- Rapid, economic and safe installation
- Reduces health and safety risks on site
- Suitable for adoptive land and private pumping stations
- Superior hydraulic performance
- Reduces construction time and costs
- Readily available

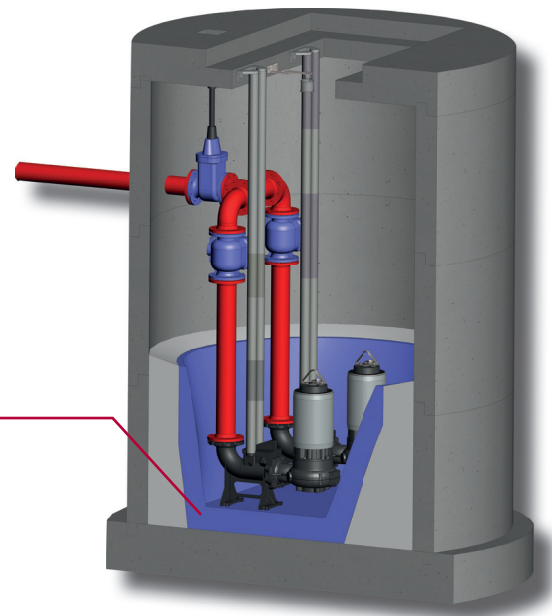
A unique design that incorporates the key features required for sewage, drainage and effluent pumping stations and that meets the adoptable standards demanded by the water companies. These engineered sumps are produced to high standards with a quality controlled process using precision tools. They have been specifically designed and built with efficiency and cost saving in mind.

As a standard product the Ready Sump® is a stock item and available for delivery to your site on short lead times to suit your requirements. Sealed concrete rings, traditional non sealed concrete rings, cover slabs and inlet chambers are available options.

- Adoptable Pumping Stations
- Non-adoptable Pumping Stations - Drainage Pumping Stations



Pre-Cast Pump Sump

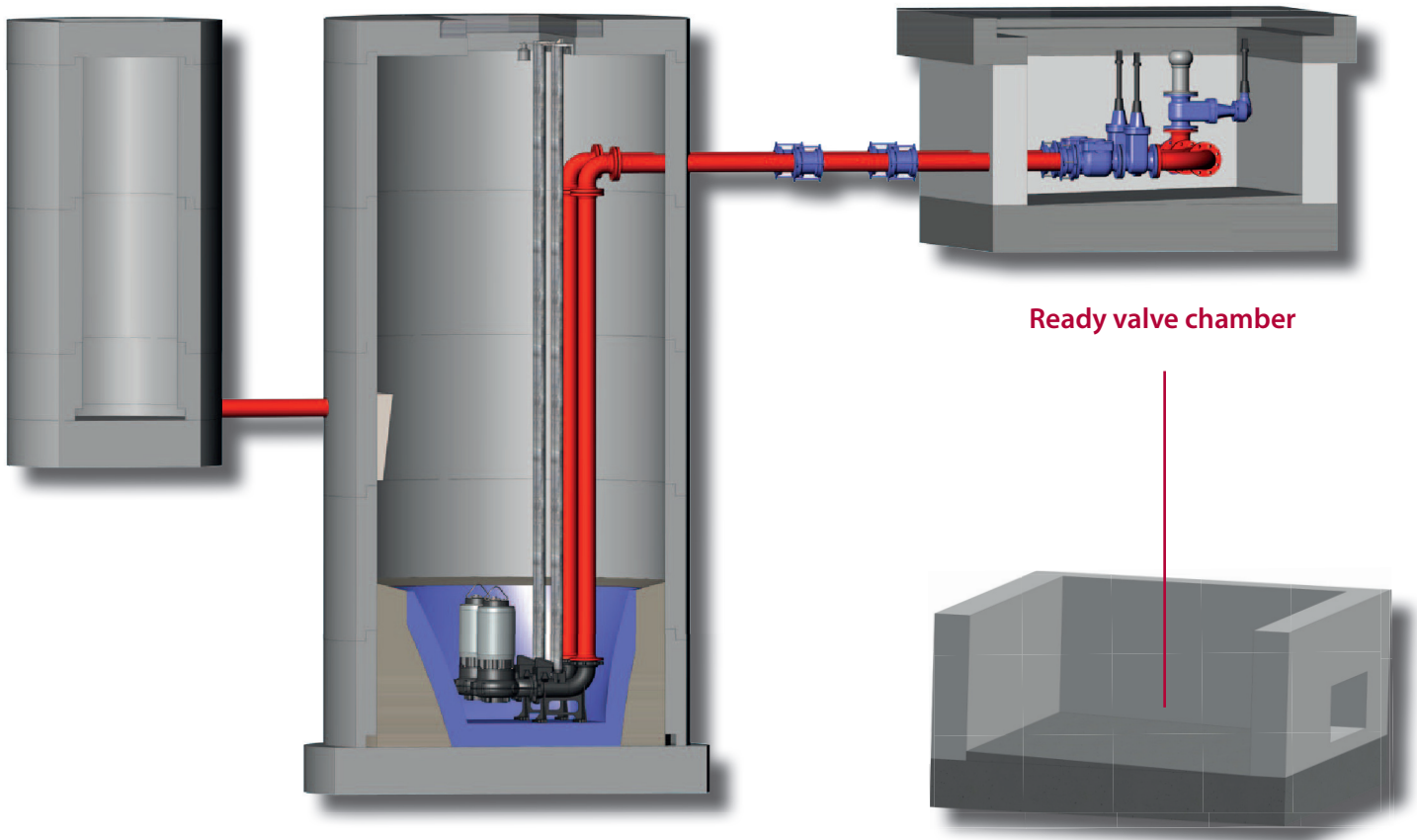


When there is no requirement for the pumping station to be adopted by the local water company the Ready Sump® still provides an economic basis for your pumping station. The pumping station has the virtues of good hydraulic design and associated performances.

The basic Ready Sump® can be incorporated into a standard 1800mm concrete ring or into a larger design where greater drainage volumes are required.

# READY SUMP®

The demands of the latest Sewers For Adoption Guide (SFA) requires sump chambers to incorporate a number of key features including benching inclines and positioning of the submersible pumps, all this of which the Ready Sump® accommodates. With the engineered design and smooth finish the Ready Sump® provides the efficient and clean centre of the pumping station.



## Ready valve chamber

The Ready Valve Chamber® is essential when constructing a pumping station to the requirement of the SFA guide. Incorporating all the features of a valve chamber and has the flexibility to accommodate various rising main outlets to meet site specifics for right or left hand and straight on connection.

A logical choice, the Ready Valve Chamber® with its factory produced accuracy, clean lines and compliance is an economical solution that is readily available. It is provided as a flat pack for easy assembly within an hour, with no special tooling required.

Size 2400mm x 1800mm

Depths can be made to suit

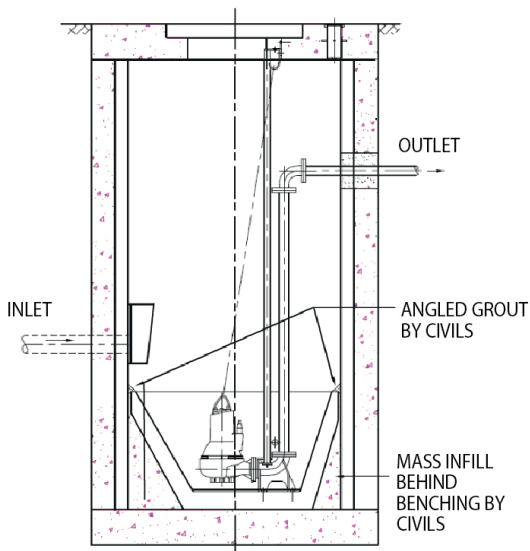
Other sizes available on request

**Convey Control Store Treat Release**

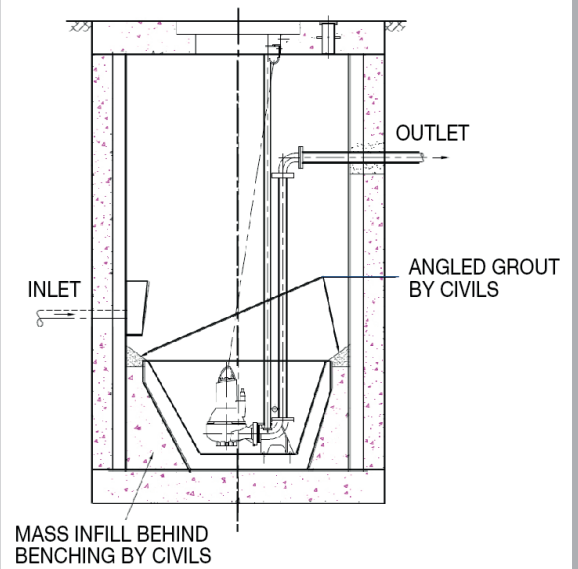
## Customised Design

The basic Ready Sump® can be incorporated into a standard 1800mm concrete ring or into a larger design where greater drainage volumes are required.

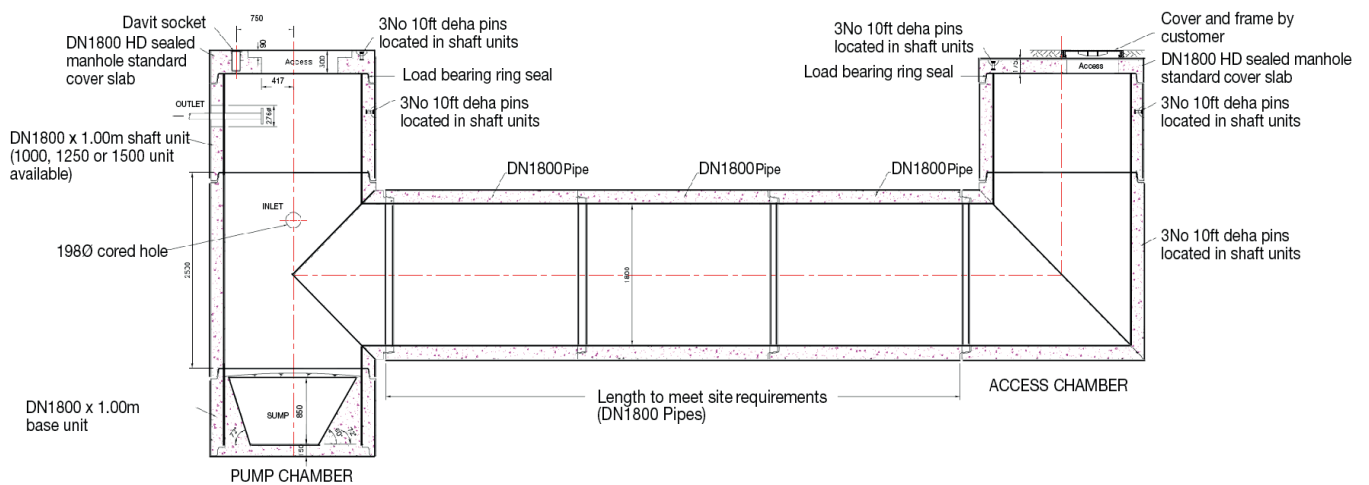
### 1800mm Plus Pump Chamber



### 2100mm Pump Chamber



### Special design for greater storage



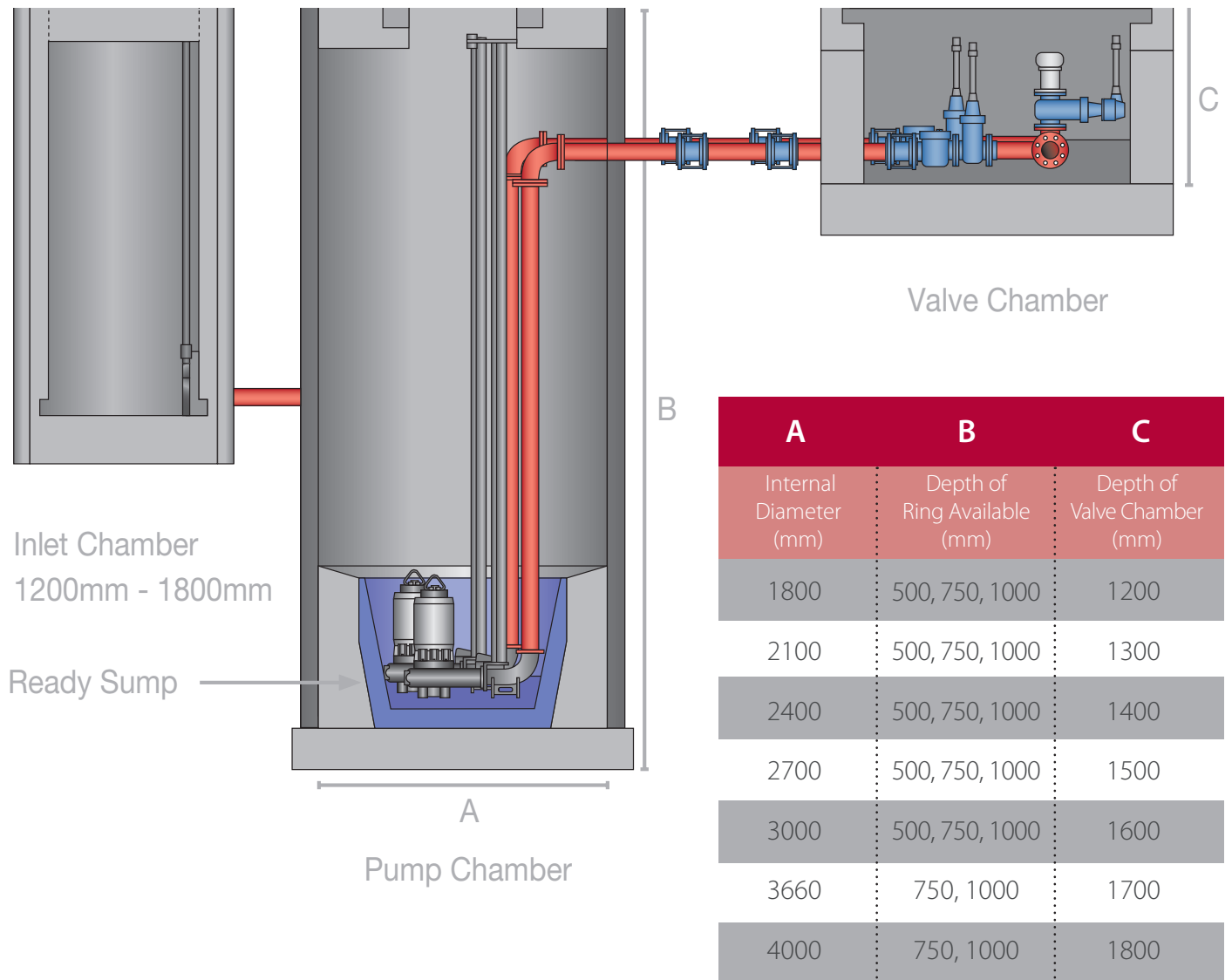


# The full package including the Ready Sump<sup>®</sup>



T-T Pumping Stations are able to provide the complete design and supply of the whole package, civil, mechanical and electrical components, with confidence.

With each unit being adapted to suit individual requirements at manufacturing stage our cost effective solution will take care of the construction, mechanical and electrical installation and commissioning. Overall T-T Pumping Stations offer an efficient solution with reduced civil costs and labour.



**Convey Control Store Treat Release**

## Ready Sump / Options



- 1500mm sealed Ready Sump complete with 850/950mm pump base and 63° benched inlet slope.
- 1800mm sealed Ready Sump complete with 1000/1300mm pump base and 60° benched inlet slope.



- Ready Sump complete with 900/1100mm pump base and 60° benched inlet slope.  
\*Can be fitted into any wet well 2100mm +
- Ready Sump complete with 1000/1300mm pump base and 60° benched inlet slope  
\*Can be fitted into any wet well 2100mm +



# Pumping stations with confidence



Convey Control Store Treat Release

## Complete UK Coverage

### ENGLAND / WALES SALES AND SOUTHERN WORKS

Marshalls CPM, Mells Road, Mells,  
Nr Frome, Somerset, BA11 3PD  
Tel: 01179 814500 Fax: 01179 814511

### NORTHERN WORKS

Marshalls CPM, Pollington, Goole,  
East Riding of Yorkshire, DN14 0DU  
Tel: 01405 860591 Fax: 01405 863606

### SCOTLAND SALES

Marshalls CPM, 101 Main Street, Newmains,  
Wishaw, Lanarkshire, ML2 9BG  
Tel: 01698 386922 Fax: 01698 387167

### PERFECT MANHOLE SALES

Marshalls CPM, 1st Floor Alexandra Mill,  
Queen Street, Leek,  
Staffordshire, ST13 6LP  
Tel: 01538 380500 Fax: 01538 380510

### TECHNICAL OFFICES

Marshalls CPM, CPM House,  
Heath Mill Road, Wombourne,  
Staffordshire, WV5 8AP  
Tel: 01902 356220 Fax: 01902 356221

