

Top Level BOM Table					
ITEM NO.	AX AJB	Description	Approx. Weight	QTY	Despatch Component Check
1	DI-SE-00103	DIST V-Tim 470 SB MS Top 2.0m Iroko FSC G&PC	90	1	
2	DI-SE-00026	DIST V-Tim 470 Bench & Seat MS L-Leg SM G&PC	9	2	

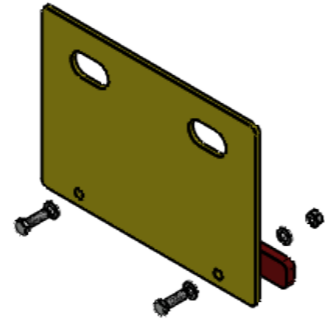

**LIFTING KIT ASSY
(EXPLODED VIEW)**
SCALE 1 : 10

**OPTIONAL EXTRA
LIFTING KIT SET**

LIFTING KITS ARE **NOT** SUPPLIED AS STANDARD BUT ARE SOLD AS AN OPTIONAL EXTRA TO HELP AID INSTALLATION. PLEASE CONSULT WITH A MEMBER OF THE SALES TEAM WHEN PLACING AN ORDER AND REFERENCE DI-SE-00108.

NOTE: EACH LIFTING KIT SET CONTAINS 2 OFF LIFTING KITS.

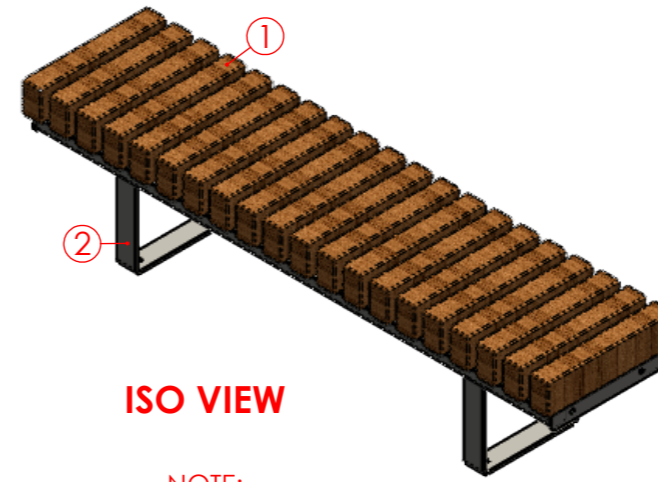

ISO VIEW

NOTE:
DISPLAY STATE FOR ILLUSTRATION
PURPOSES ONLY

PRODUCT SPECIFICATION

TIMBER

MATERIAL:

Slats - Iroko FSC

FINISH:

Planed & untreated.

EDGE DETAIL:

Pencil (all edges).

STEELWORK

MATERIAL:

Sub Frame & Legs - Mild Steel

GRADE:

Sub Frame - S235 & S275
Legs - S275

FINISH:

Hot Dipped Galvanised (BS EN ISO 1461:1999) and Polyester Powder Coated to a standard catalogue colour (default RAL 9007 Matt).

DIMENSIONS:

Width Overall: 470mm
Length Overall: 1970mm
Seating Height: 480mm
Height Above Ground: 480mm
Height Overall: 480mm

FIXING TYPE:

Surface Mount

APPROX WEIGHT:

108 kg

FOUNDATIONS:

Concrete grade C16/20 mass fill.

Foundation sizes given are suited to sub-soils with good load bearing capabilities. Where adverse site conditions are met professional advice to be sought.

INSTALLATION:

- Excavate suitable foundation as shown.
- Cast concrete C16/20.
- Allow foundations to cure.
- Position product and bolt to pads.

NOTE: Lifting Kits are **not** included as standard and must be purchased separately as an optional extra.

For operation and maintenance please refer to the **Marshalls Street Furniture Maintenance Guide**.

Unless otherwise stated: All Dimensions are in Millimetres

Marshalls PLC reserves the right to change the specifications of any product detailed without prior notice.

Rev	Init	Revision Notes	ER No.	Date
B	GE	Main profile thickness reduced to 3mm. Spacers removed.		26/11/2020

Title:
DIST V-Tim 470 SB MS 2.0m LL SM Iroko FSC G&PC

Drawing No:
PS-DI-SE-00091

	Premier Way, Lowfields Business Park, Elland, Halifax, West Yorks, HX5 9HT	TEL: 0870 600 2426 EMAIL: mst.sales@marshalls.co.uk www.marshalls.co.uk/commercial

DRAWN BY: GE **DATE:** 22/09/2020

DO NOT SCALE DRAWING **REVISION:** [B]

SCALE: 1:20@A3 **SHEET:** 1 of 1

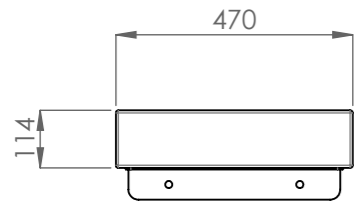

**470 BENCH TOP TYP
SIDE PROFILE**
SCALE 1 : 15

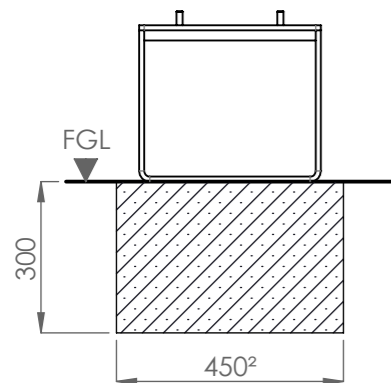
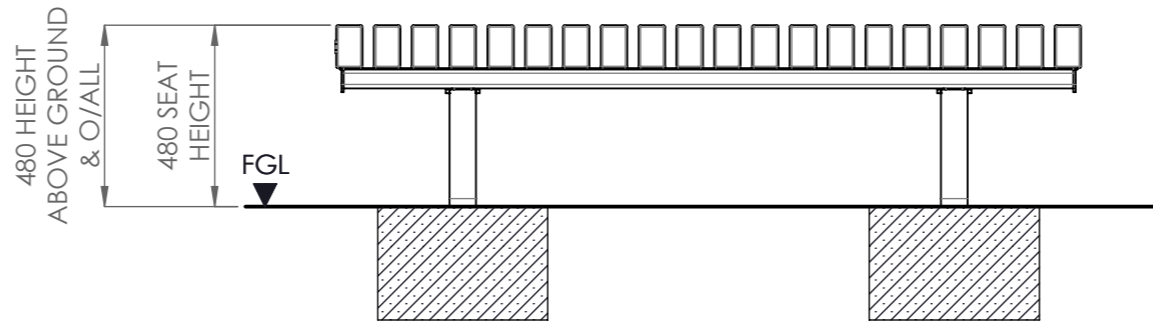
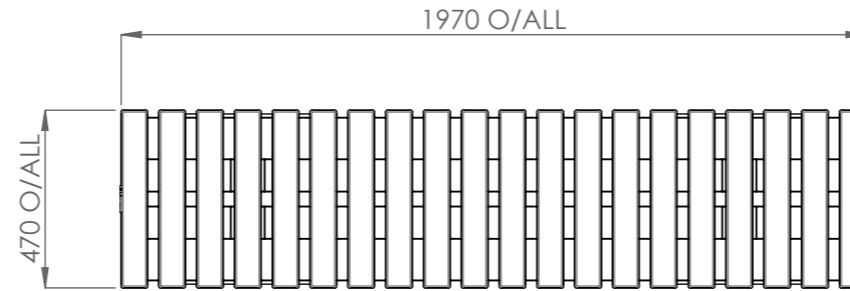

TYP FOUNDATION DETAIL
SCALE 1 : 15

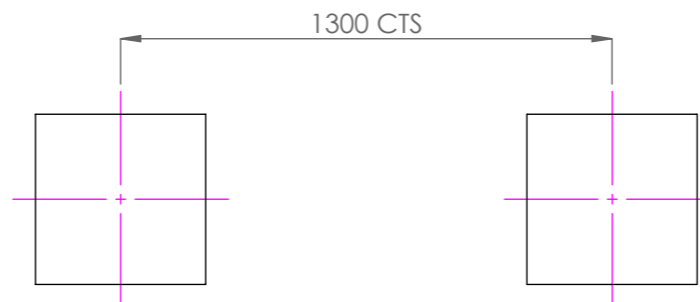

FOUNDATION LAYOUT