

**470 BENCH TOP WITH ARMREST
TYP SIDE PROFILE**
SCALE 1 : 15

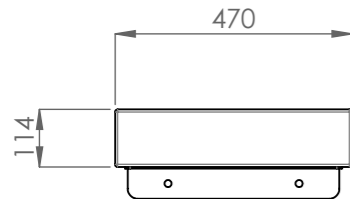

**470 BENCH TOP TYP
SIDE PROFILE**
SCALE 1 : 15

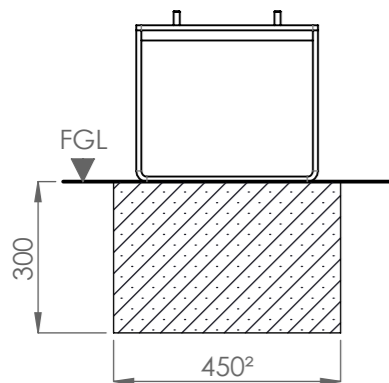

TYP FOUNDATION DETAIL
SCALE 1 : 15

Component BOM Table					
ITEM NO.	AX AJB	Description	Approx. Weight	QTY	Despatch Component Check
1	DI-SE-00114	DIST V-Tim 470 CB MS Top 1.3m IR 90° Iroko FSC T2 G&PC	131	1	
2	DI-SE-00026	DIST V-Tim 470 Bench & Seat MS L-Leg SM G&PC	9	3	

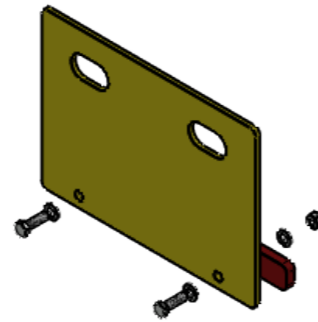

**LIFTING KIT ASSY
(EXPLODED VIEW)**
SCALE 1 : 10

**OPTIONAL EXTRA
LIFTING KIT SET**

LIFTING KITS ARE **NOT** SUPPLIED AS STANDARD BUT ARE SOLD AS AN OPTIONAL EXTRA TO HELP AID INSTALLATION. PLEASE CONSULT WITH A MEMBER OF THE SALES TEAM WHEN PLACING AN ORDER AND REFERENCE DI-SE-00108.

NOTE: EACH LIFTING KIT SET CONTAINS 2 OFF LIFTING KITS.

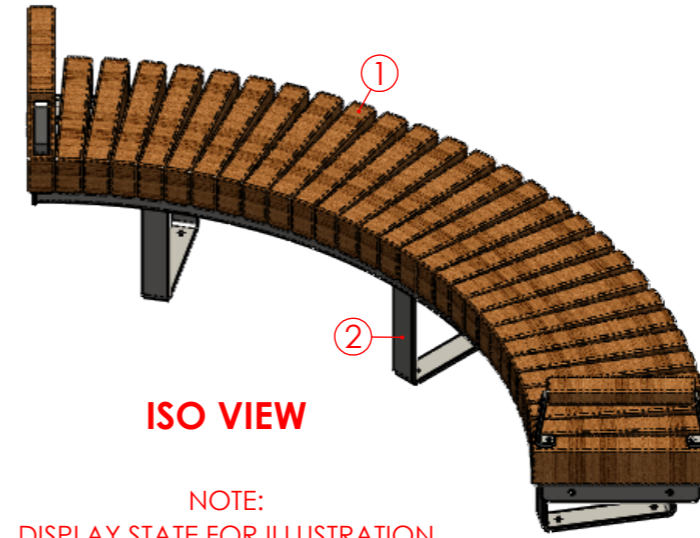

ISO VIEW

NOTE:
DISPLAY STATE FOR ILLUSTRATION
PURPOSES ONLY

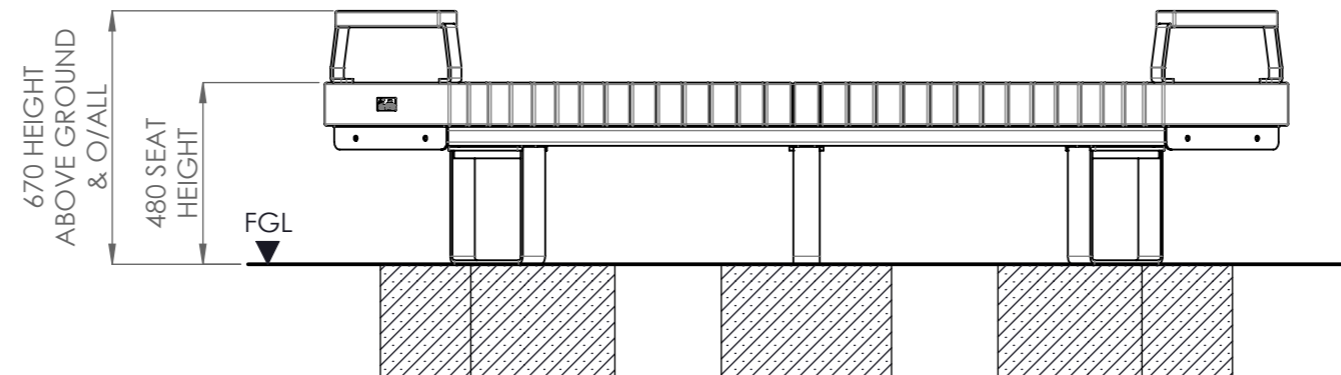
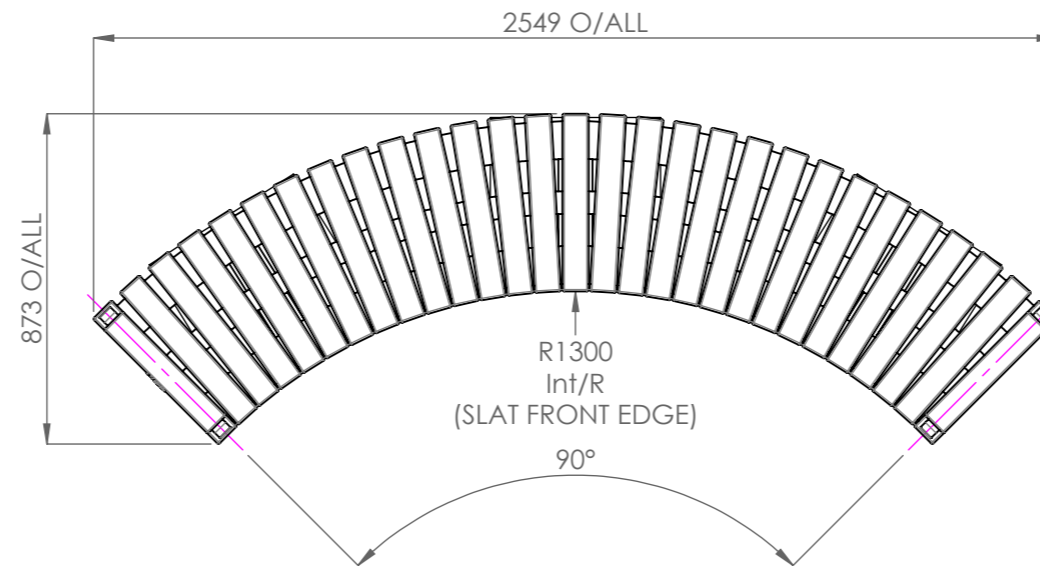

PRODUCT SPECIFICATION

TIMBER

MATERIAL:

Slats & Armrest Pads - Iroko FSC

FINISH:

Planed & untreated.

EDGE DETAIL:

Pencil (all edges).

STEELWORK

MATERIAL:

Sub Frame, Armrest Straps & Legs - Mild Steel

GRADE:

Sub Frame - S235 & S275

Armrest Straps - S275

Legs - S275

FINISH:

Hot Dipped Galvanised (BS EN ISO 1461:1999) and Polyester Powder Coated to a standard catalogue colour (default RAL 9007 Matt).

DIMENSIONS:

Width Overall: 873mm

Length Overall: 2549mm

Seating Height: 480mm

Height Above Ground: 670mm

Height Overall: 670mm

FIXING TYPE:

Surface Mount

APPROX WEIGHT:

158 kg

FOUNDATIONS:

Concrete grade C16/20 mass fill.

Foundation sizes given are suited to sub-soils with good load bearing capabilities. Where adverse site conditions are met professional advice to be sought.

INSTALLATION:

1. Excavate suitable foundation as shown.
2. Cast concrete C16/20.
3. Allow foundations to cure.
4. Position product and bolt to pads.

NOTE: Lifting Kits are **not** included as standard and must be purchased separately as an optional extra.

For operation and maintenance please refer to the **Marshalls Street Furniture Maintenance Guide**.

Unless otherwise stated: All Dimensions are in Millimetres

Marshalls PLC reserves the right to change the specifications of any product detailed without prior notice.

Rev	GE	Main profile thickness reduced to 3mm. Spacers removed.	26/11/2020
Rev	Init	Revision Notes	ER No. Date

Title:
DIST V-Tim 470 CB MS 1.3m IR 90° LL SM
Iroko FSC T2 G&PC

Drawing No:
PS-DI-SE-00097

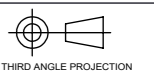

Marshalls
Premier Way,
Lowfields Business Park,
Elland, Halifax,
West Yorks, HX5 9HT
TEL: 0870 600 2426
EMAIL: mst.sales@marshalls.co.uk
www.marshalls.co.uk/commercial

DRAWN BY: GE **DATE:** 23/09/2020

DO NOT SCALE DRAWING

REVISION:

SCALE: 1:20@A3 **SHEET:** 1 of 2

[B]

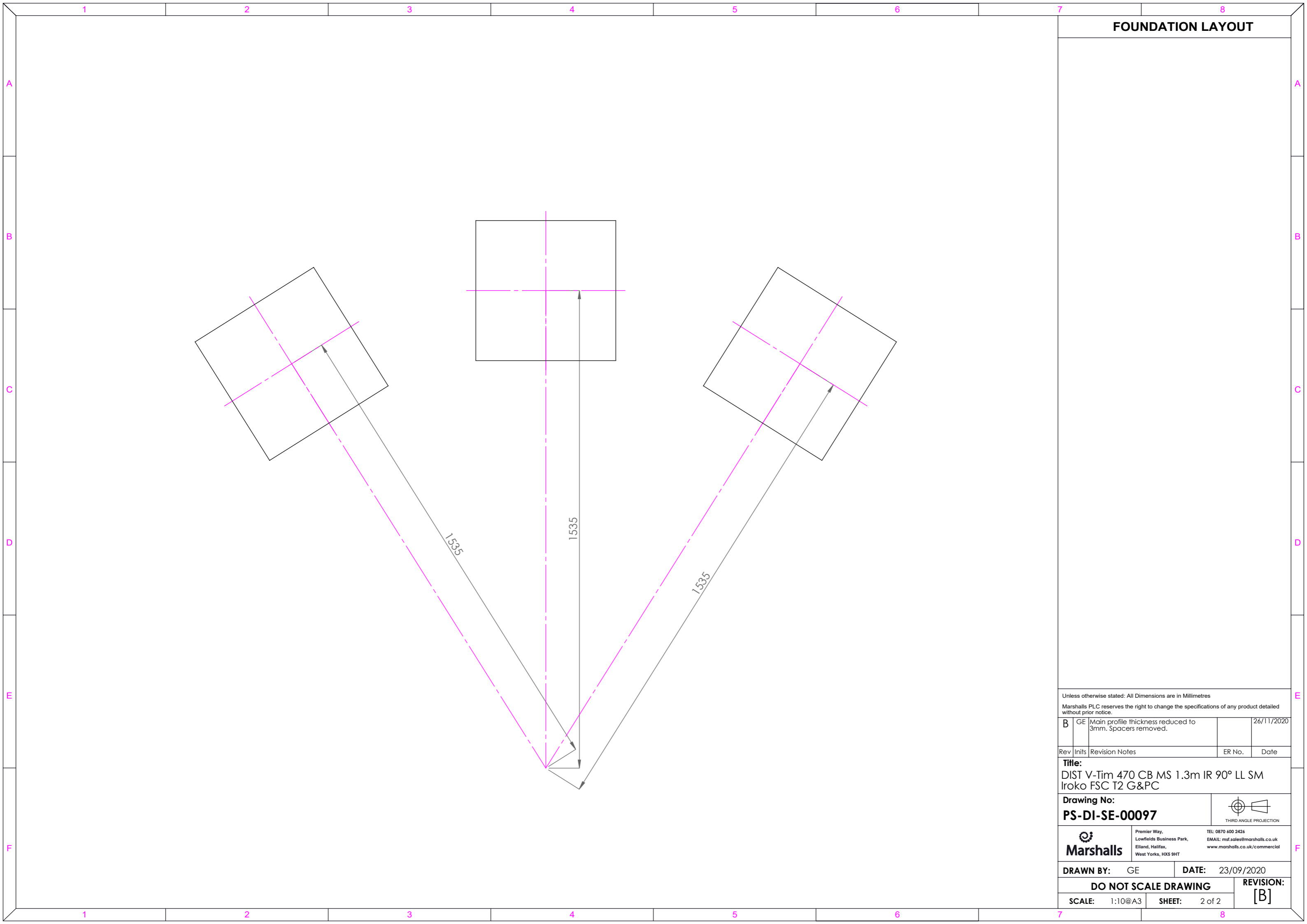

FOUNDATION LAYOUT

Unless otherwise stated: All Dimensions are in Millimetres
 Marshalls PLC reserves the right to change the specifications of any product detailed without prior notice.

Rev	Units	Revision Notes	ER No.	Date
B	GE	Main profile thickness reduced to 3mm. Spacers removed.		26/11/2020

Title:
 DIST V-Tim 470 CB MS 1.3m IR 90° LL SM
 Iroko FSC T2 G&PC

Drawing No:
PS-DI-SE-00097

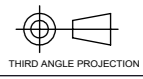

	Premier Way, Lowfields Business Park, Elland, Halifax, West Yorks, HX5 9HT	TEL: 0870 600 2424 EMAIL: mst.sales@marshalls.co.uk www.marshalls.co.uk/commercial
	DRAWN BY: GE DATE: 23/09/2020	

DO NOT SCALE DRAWING		REVISION: [B]
SCALE: 1:10@A3	SHEET: 2 of 2	