

ITEM NAME	ITEM CODE
RG Verso 1800 Curve 15-30 - Complete - Silver Grey	VR-SE-00022
RG Verso 1800 Curve 15-30 - Complete - City Grey	VR-SE-00026
RG Verso 1800 Curve 15-30 - Complete - Anthracite	VR-SE-00030

**PRODUCT SPECIFICATION**

**MATERIAL:**  
Concrete

**FINISH:**  
Silver Grey

**FIXING TYPE:**  
Root Fix Foundation

**APPROX WEIGHT:**  
Block - **1591kg**  
Core - **25kg** (Each)

**FOUNDATIONS:**

Concrete grade C30 mass fill **600 x 600 x 250**.

Ground to be flat and level.  
Ensure ground has sufficient load bearing capability to support the weight of the product. Where adverse site conditions are met professional advice to be sought.

- INSTALLATION:**
1. Excavate suitable foundation as shown.
  2. Cast concrete C30 around core.
  3. Allow foundations to cure.
  4. Attach M30 Lifting eyes (1 off).
  5. Lower concrete block over ground frame.
  6. Remove Lifting eye and secure using M20 Bolt.
  7. Fit Lifting point plugs (1 off).

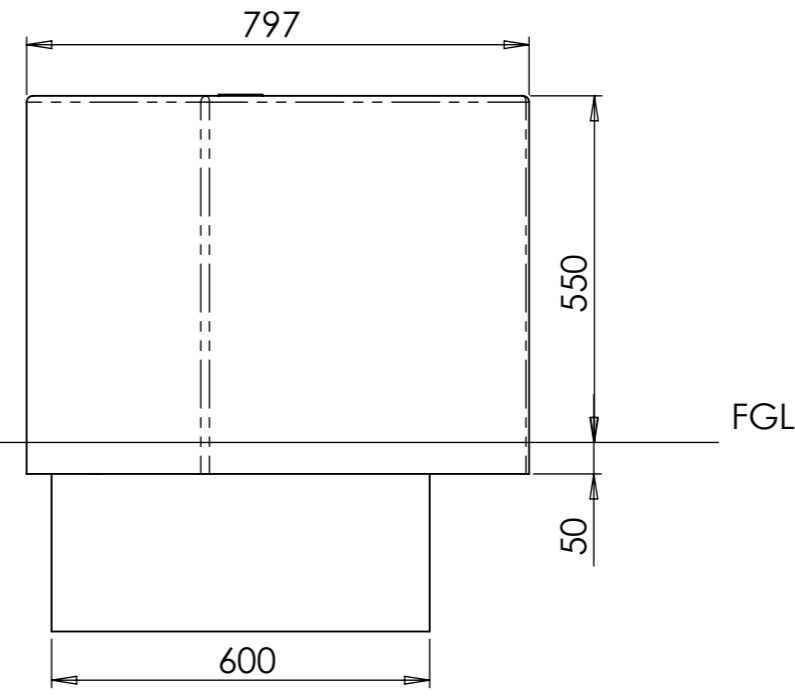
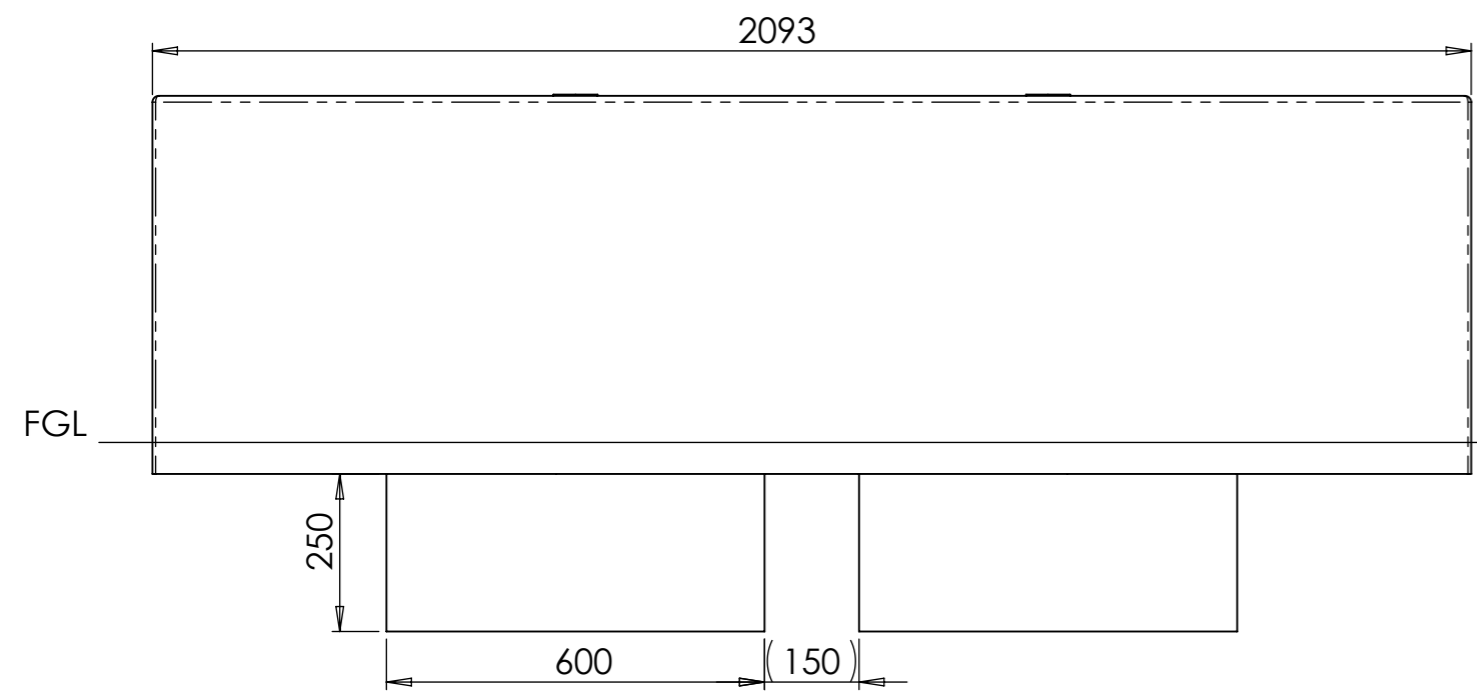
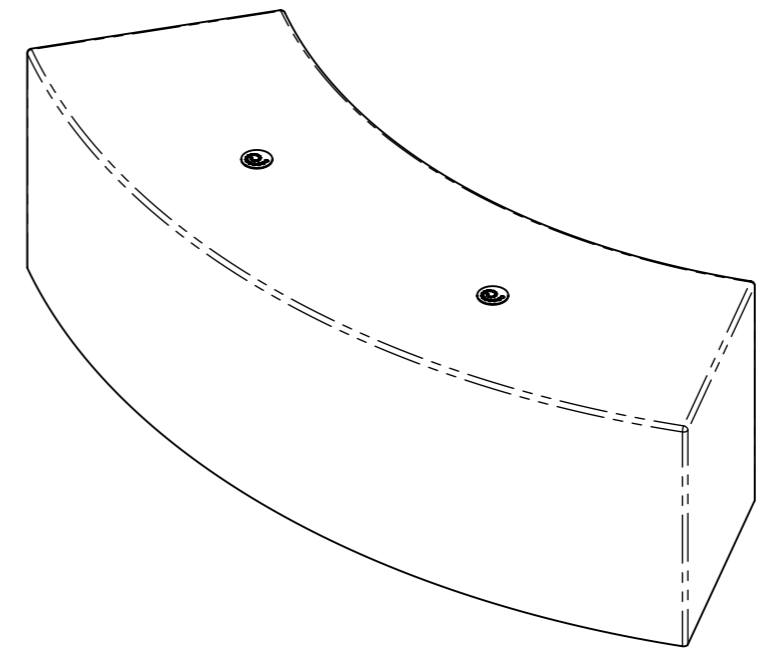
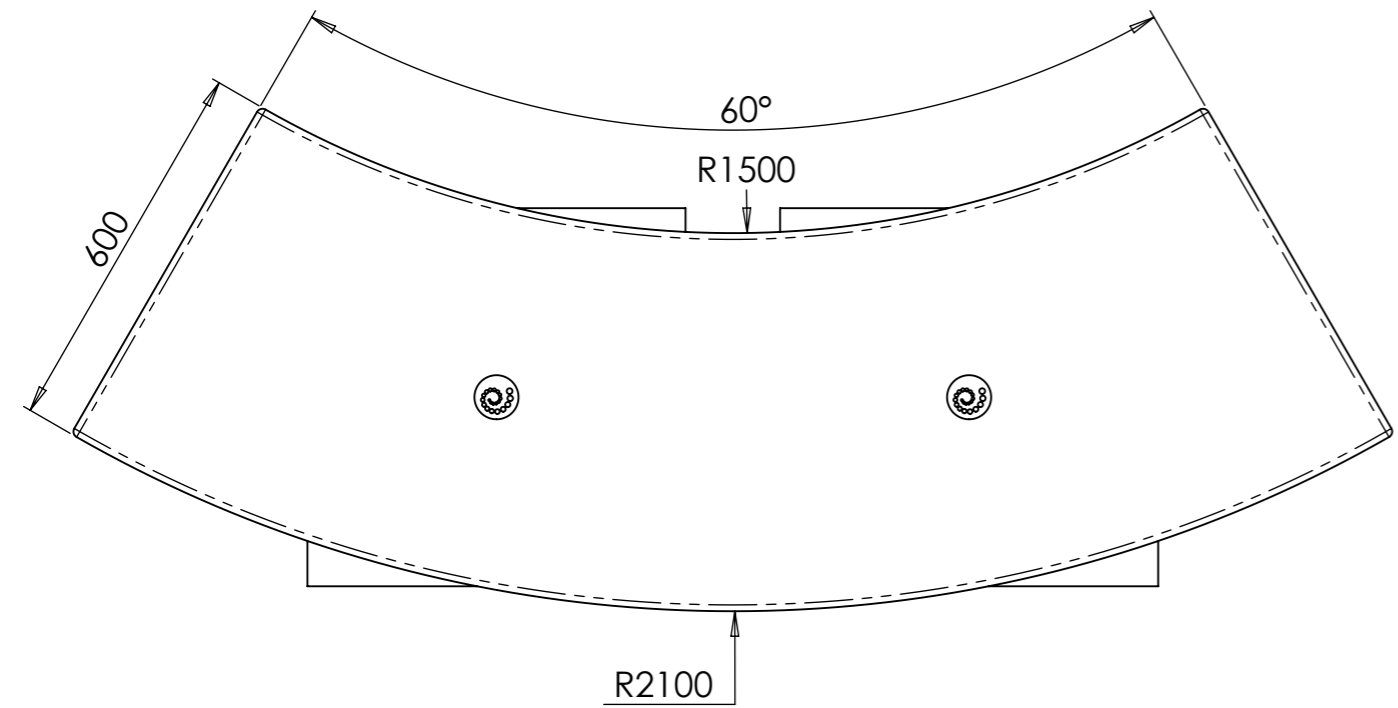

For operation and maintenance please refer to the **Marshalls Street Furniture Maintenance Guide**.

Unless otherwise stated: All Dimensions are in Millimetres  
Marshalls PLC reserves the right to change the specifications of any product detailed without prior notice.

Rev	Init	Revision Notes	ER No.	Date
A	HP	1st Release		11/03/2021

**Title:**  
RG Verso 1800 Curve 15-30 Block - Complete

**Drawing No:**  
**PS-VR-SE-00022**

**Marshalls**  
Premier Way,  
Lowfields Business Park,  
Elland, Halifax,  
West Yorks, HX5 9HT

TEL: 0870 600 2424  
EMAIL: [mst.sales@marshalls.co.uk](mailto:mst.sales@marshalls.co.uk)  
[www.marshalls.co.uk/commercial](http://www.marshalls.co.uk/commercial)

**DRAWN BY:** HP **DATE:** 11/03/2021

**DO NOT SCALE DRAWING**

**SCALE:** 1:12@A3 **SHEET:** 1 of 2 **REVISION:** [A]