

ITEM NAME	ITEM CODE
VERSO 1200 Double Bench Top - WPC	VR-SE-00053
VERSO 1200 Double Bench Top cw End Arms - WPC	VR-SE-00054
VERSO 1200 Double Bench Top cw Full Arms - WPC	VR-SE-00055

PRODUCT SPECIFICATION

MATERIAL:
Concrete

FINISH:
Silver Grey

FIXING TYPE:
Root Fix Foundation

APPROX WEIGHT:
50 kg

FOUNDATIONS:

Concrete grade C16/20 mass fill **1200 x 600 x 250.**

Ground to be flat and level.
Ensure ground has sufficient load bearing capability to support the weight of the product. Where adverse site conditions are met professional advice to be sought.

- INSTALLATION:**
1. Install 1200 Concrete block with chosen protective rating.
 2. Lift product onto existing concrete block.
 3. Mark hole positions onto concrete and remove bench.
 4. Drill holes and insert Hilti Drop in Anchors (4 off) or similar.
 5. Reposition bench body and secure using M8 Screw (4 off) + M8 Washers (4 off).

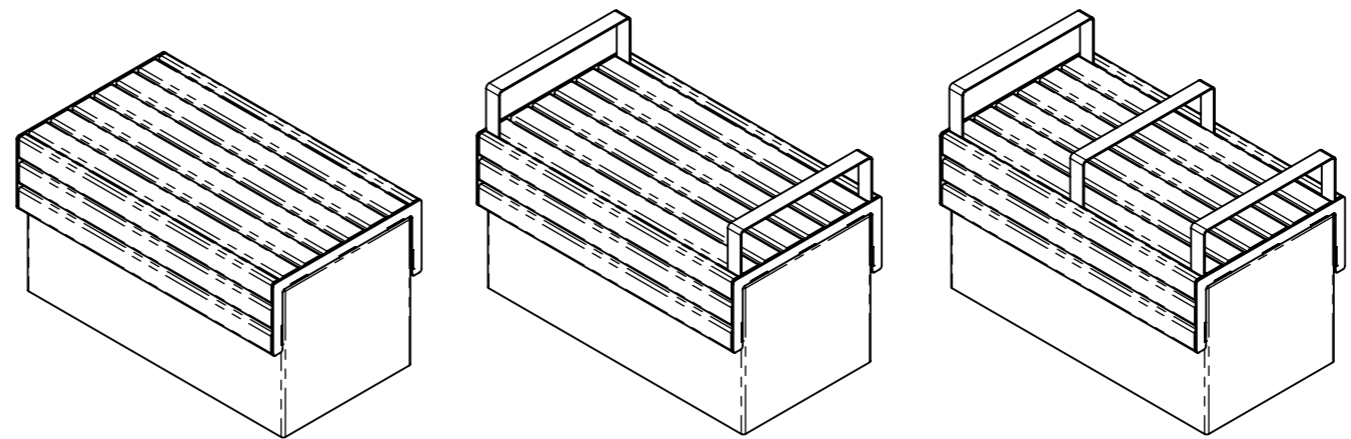

PLAIN

END ARMS

FULL ARMS

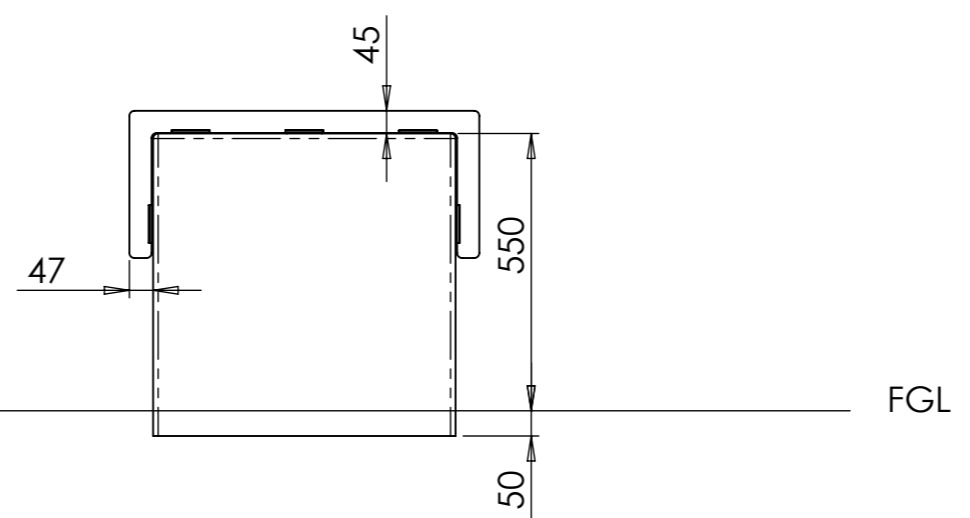
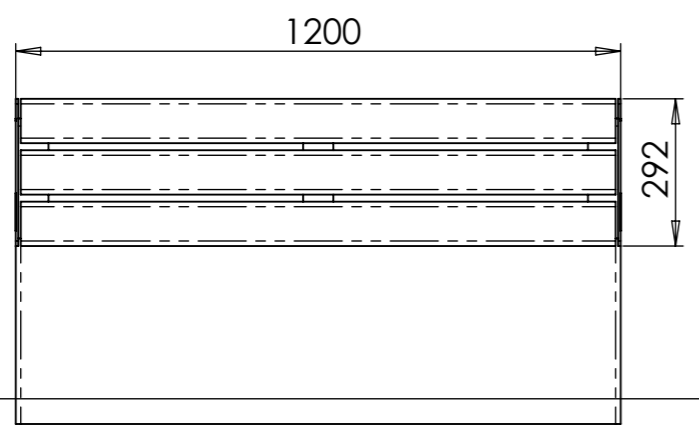
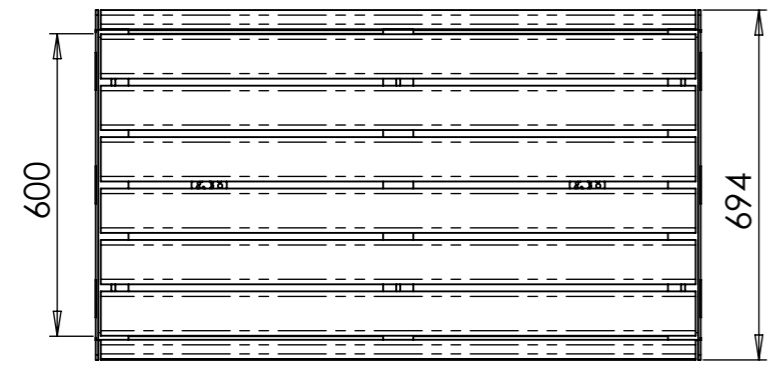

FGL

FGL

ITEM NO.	PART NUMBER	DESCRIPTION	QTY.
1	VR-SE-00053	VERSO - 1200 Double Bench Top - WPC	1
3	XX-F05-10110	M8 Spring Washer	4
4	XX-F03-10103	M8 X 16 Skt Cap Screw	4
5	XX-F10-10192	Hilti HKD-SR Drop in Anchor M8 x 30	4

For operation and maintenance please refer to the **Marshalls Street Furniture Maintenance Guide.**

Unless otherwise stated: All Dimensions are in Millimetres
Marshalls PLC reserves the right to change the specifications of any product detailed without prior notice.

Rev	Init	Revision Notes	ER No.	Date
A	HP	1st Release		07/07/2021

Title:
Verso 1200 Double Bench Top - WPC

Drawing No:
PS-VR-SE-00053

Marshalls
Premier Way,
Lowfields Business Park,
Elland, Halifax,
West Yorks, HX5 9HT

TEL: 0870 600 2426
EMAIL: mst.sales@marshalls.co.uk
www.marshalls.co.uk/commercial

DRAWN BY: HP **DATE:** 07/07/2021

DO NOT SCALE DRAWING **REVISION:** [A]

SCALE: 1:15@A3 **SHEET:** 1 of 1