

Water Management Shaft Installation Guide

DN2100 - DN3000 Units



1.0 Introduction

- Marshalls Civils & Drainage concrete manholes are designed, manufactured and kitemarked to BS EN 1917 and BS5911-3. The intended use is to permit access and to allow aeration of drain or sewer systems conveying sewage or surface water under gravity.
- When correctly installed the manhole units are designed to withstand main road traffic loading. For further details of the specification and performance criteria please see the attached Data Sheet or contact Marshalls Civils & Drainage Technical Department for further information.
- Please note this is a general guide and reference to drawings and specification should be made for any particular requirements.
- Marshalls Civils & Drainage is committed that its products are designed and manufactured to ensure the safety of users. Installation of products involves breaking ground and is thus considered as construction work under the Construction (Design and Management) Regulations 2015.
- Marshalls Civils & Drainage puts a great deal of effort into ensuring that its designs are safe and will provide structural details to the Principal Designer nominated by the Construction Site Client, if requested (please contact Marshalls Civils & Drainage team on 0333 220 2735 or civildrainagesales@marshalls.co.uk).

2.0 Preparatory Considerations

- Instructions should be read in conjunction with the Marshalls Civils & Drainage product data sheet and technical drawing.
- Marshalls Civils & Drainage recommends that ALL lifting operations should comply with the Lifting Operations and Lifting Equipment Regulations (LOLER) 1998, and the Provision and Use of Work Equipment Regulations 1998 (PUWER).
- For the excavation work required prior to manhole construction a mechanical excavator is normally required. The type is dependant on the manhole diameter and weight (see table).
- For water management shaft manhole rings and cover slabs from 2100 to 3000 a 360° slew machine or crane will be required.
- The bucket of any excavator being used should be fitted with an approved lifting point to which the chains or webbing sling can be attached. **DO NOT USE MAKESHIFT LIFTING ARRANGEMENTS.**

3.0 Off Loading

- Chamber sections should be delivered vertically on the lorry. Proprietary lifting fittings are required (available from your supplier) which screw into the four cast-in inserts on the top face of each manhole section.



- Lifting chains with hooks will be required to utilise the screw in lift points.
- Base slabs and Cover slabs have 3 lifting points cast-in to their top surface also requiring lifting chains with hooks.



IT IS ESSENTIAL FOR THE LIFTING CHAINS TO HAVE A SAFE WORKING LOAD AND SUITABLE ANGLE OF LIFT APPROPRIATE FOR THE UNIT BEING LIFTED.

SHAFT DIAMETER	Chamber Unit Weight - tonnes	Cover Slab Weight - kg (675 ² access)	Base Slab Weight - tonnes	Down Stream Defender Weight- tonnes
2100	3.9t	1745	2.8t	
2400	4.5t	2375	3.4t	4.7t
2700	5.0t	3335	4.1t	
3000	7.5t	4585	5.7t	7.7t

4.0 Construction

The manhole can be built off either:

- Minimum 200mm pipe granular bedding material being 5-20 graded, 14, 20,40mm single size suitably compacted to provide a level base. Alternatively a Class 6N or 6L material can be used.
- 200mm GEN 1(C8/10) concrete. Base unit should be placed whilst concrete is wet so it can be set level otherwise a levelling screed of 15- 20mm sand cement will be required to prevent point loading on the base unit

Note: In poor or wet ground conditions a concrete pad is advised. Normally a granular bedding is recommended where the safe ground bearing pressure >200kN/m². Advice is available should it be needed.

Care should be taken to ensure the base slab central rebate is laid in the correct orientation to accommodate any weir-wall position where required.

- The 120 x 12mm jointing sealant provided should be laid around the base slabs rebated circumference so that it is directly below the first shaft section to

be installed. Four of the circular 5mm thick spacer washers provided should be placed at equal spacing around the sealants circumference to ensure an even minimum joint gap when the two units are together and under compression load. Ensure that the ends of the jointing material are overlapped by 50mm to provide a good seal.

- To install the first shaft section onto the base slab, four M30 lifting fittings should be fully screwed into the threaded inserts cast-in to the shaft sections top surface. Appropriate chains with hooks can then be used to carry out the lift and install.



- Following the first shaft sections placement, the four plastic protection caps fitted in the section top jointing surface should be removed to allow the stainless steel jointing dowel pins to be inserted. The four EPDM spacing washers provided should then be placed over the dowel pins to lie flat against the concrete surface.

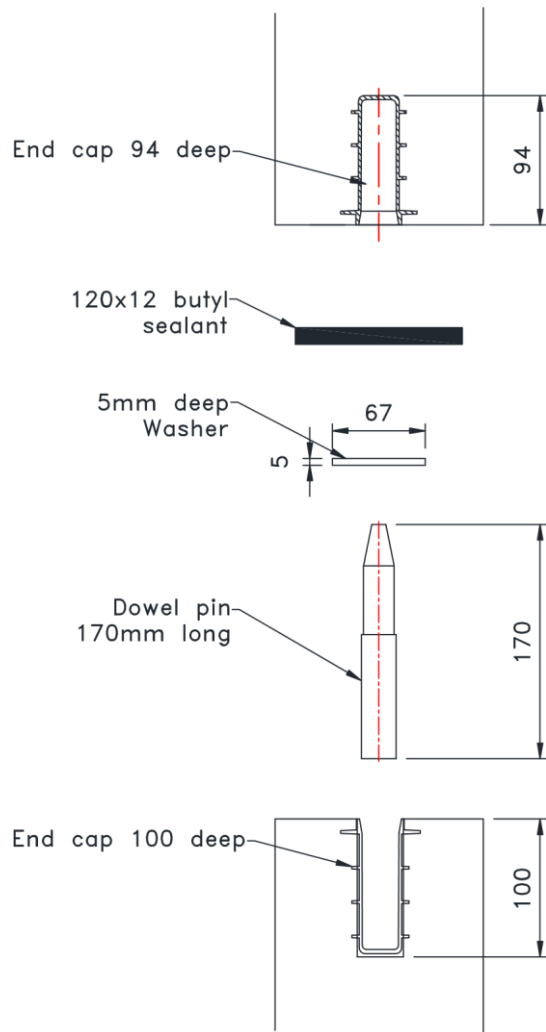

- The sealing material can then be laid around the sections joint circumference, taking care to carefully pierce the locating dowels through the material so that it lies flat against the spacing washers. The purpose of the washers is to maintain a minimum 5mm joint gap for the sealing material between the two jointed surfaces when under compression.

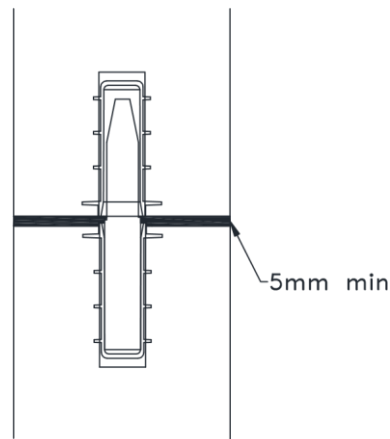

- The next shaft section can then be installed, carefully lowering the unit over the locating dowel pins while taking care to accommodate the rebated slots in the sections wall to match any weir-wall where required.
- The manhole shaft can then be constructed to the required height, repeating the jointing procedure for every section installed.
- After reaching the required shaft height, the cover slab should be installed on two layers of sealing material between the top manhole section and cover slab making sure to offset the ends of the two layers of material to ensure a good seal.
- Some specifications may require a 150mm concrete surround to the manhole. Proprietary shutters are available for this should it be required.
- The manhole shaft can then be completed to ground level by using either class B engineering bricks or precast concrete adjusting units with the access cover and frame finally seated at ground level.
- Once installed, the unit should be checked for level, after which suitable backfill can be used unless the contract requires otherwise. The units are then completed as a Water Management Shaft.

For further information please call our team on 0333 220 2735 or email civilsdrainagesales@marshalls.co.uk